

Plenum Fans

Models QEM and QEP

Belt and Direct Drive

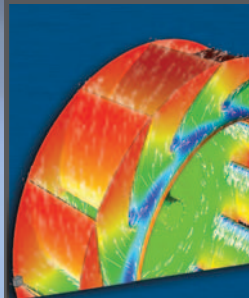
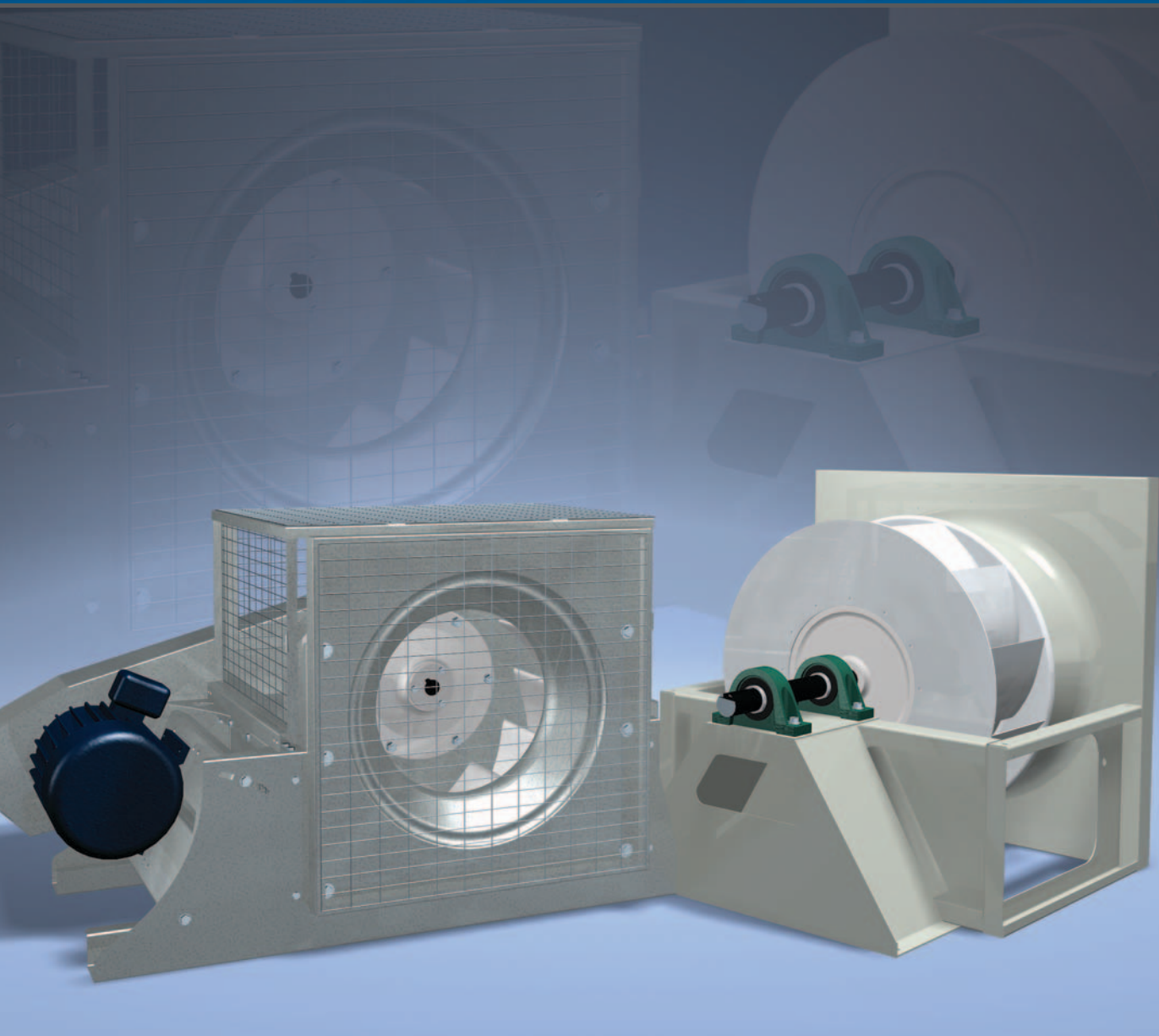

 **GREENHECK**
Building Value in Air.

September
2008

Quiet & Efficient Plenum Fans

Models QEM and QEP plenum fans are designed and engineered to provide superior performance and reliability in commercial or industrial applications. Our products are manufactured with state of the art laser, forming, spinning and welding equipment and endure our quality control testing to ensure trouble free start-up.

Plenum fans are designed to handle a variety of commercial and industrial projects. They are designed for unhused operation which results in a savings of the space normally occupied by the fan housing. Additional space savings are realized when multiple duct takeoffs are required. Ductwork is connected directly to the pressurized plenum without intermediate transitions. Typical applications include:

- Parking garages
- Packaged air handlers
- Built-up air handlers
- Custom air handlers
- General supply and return systems

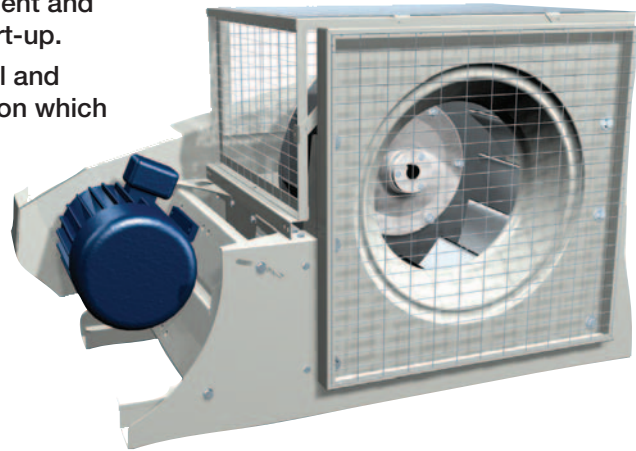

QEM arrangement 9 belt drive shown with optional guarding.

Advantages of the QEM vs. QEP

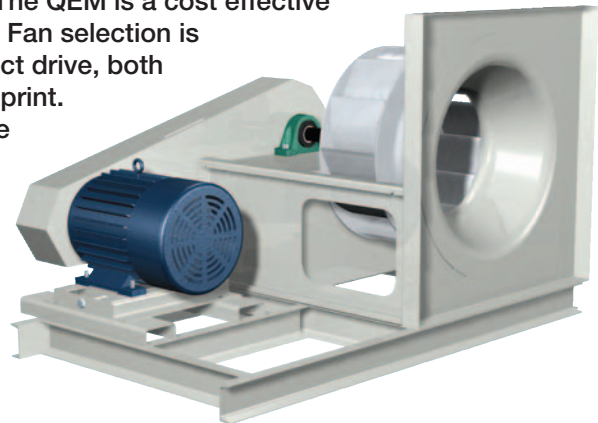

Greenheck offers two solutions for your plenum design needs. The QEM is a cost effective solution for performances in class I and most of class II as well. Fan selection is simplified with one fan design for belt drive and another for direct drive, both with motors mounted directly to the fan to reduce the fan's footprint. Both arrangements cover the entire QEM operating range. While the initial purchase cost of the QEM is lower than other plenum fans, the QEM still shares the exact same performance benefits of the high end model QEP.

Model QEP can be utilized when customers demand a premium quality product, or need to reach performances in the class III operating range. In addition to sharing the same high-efficiency and low sound wheel design as the QEM, the QEP also features longer life L₁₀ 80,000 hour bearings, a powder coat finish, as well as a wider range of mounting options and accessories.

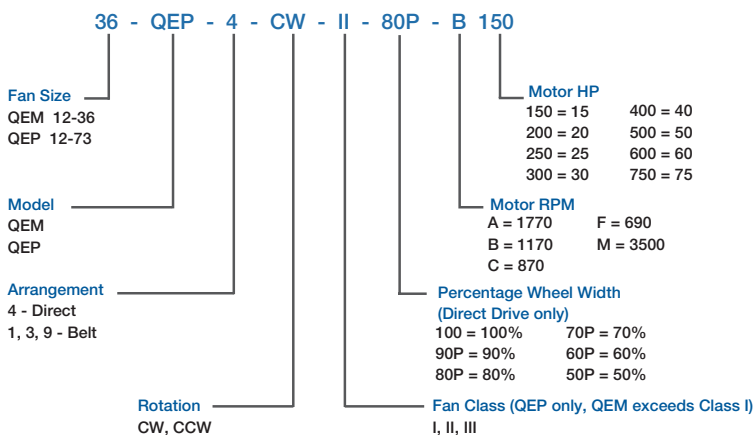

QEP arrangement 1 belt drive shown with optional structural steel base and belt guard.

Plenum Model Number Code:

Greenheck Fan Corporation certifies that the Model QEM and QEP plenum fans shown herein are licensed to bear the AMCA seal. Direct Drive models are not licensed to bear the AMCA Seal. The ratings shown are based on tests and procedures performed in accordance with AMCA Publication 211 and Publication 311 and comply with the requirements of the AMCA Certified Ratings Program.

Performance Comparison 9 vs. 12-Blade Wheels

Advantages of 12-Blade Wheels

Traditional centrifugal wheels utilize 9-blade wheel designs. While their performance is adequate, recent industry trends have seen the emergence of 12-blade wheel designs where customers demand higher mechanical efficiency and lower sound levels.

Model QEM and QEP plenum fans feature a 12-blade aluminum airfoil construction wheel. As demonstrated in Figure 1, this 12-blade design meets customer needs by providing higher efficiency, lower sound levels as well as lower energy consumption.

Greenheck's 12-blade wheel design features extruded aluminum blades up to and including size 49, while the largest sizes utilize laser cut, die-formed aluminum blades. The two performance examples below demonstrate the superior performance of the 12-blade design.



Size 18 Performance Criteria of 5,500 CFM @ 5 in. wg

Wheel Type	RPM	Brake HP	Motor HP Size	Static Eff.	LwA
9-Blade	2607	7.76	10	56%	96
12-Blade	2400	6.37	7.5	68%	90

Size 33 Performance Criteria of 21,500 CFM @ 5 in. wg

Wheel Type	RPM	Brake HP	Motor HP Size	Static Eff.	LwA
9-Blade	1469	26.9	30	63%	96
12-Blade	1416	23.9	25	71%	92

Air Performance

Figure 1 plots the fan performance and efficiency of two fans running at the same rpm. Increased wheel efficiency allows the 12-bladed fan to produce more airflow while using less energy.

Air Performance Comparison
Size 33 @ 1400 RPM

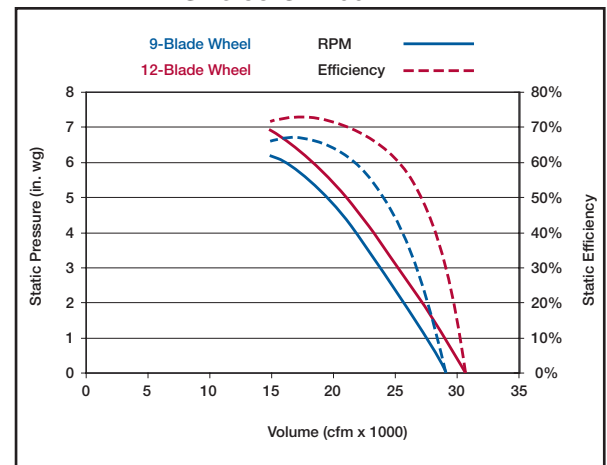

Figure 1

Sound Performance

Figures 2 and 3 show the inlet and outlet sound spectrums for the size 33 unit used in the above performance comparison.

Lower Sound Power (LwA)

The overall A-weighted sound power levels for identical performance requirements show that the 12-bladed wheel design is quieter.

Easy to Attenuate

High sound power levels in the first and second octave bands are difficult to attenuate. The 12-bladed wheel generates less low frequency sound power.

Improved Sound Quality

A sound spectrum with a dominant tone can be annoying to a listener. Greenheck's 12-bladed wheel provides balanced sound power levels across the octave bands. This results in sound that is pleasing to the listener.

Inlet Sound Comparison - Size 33

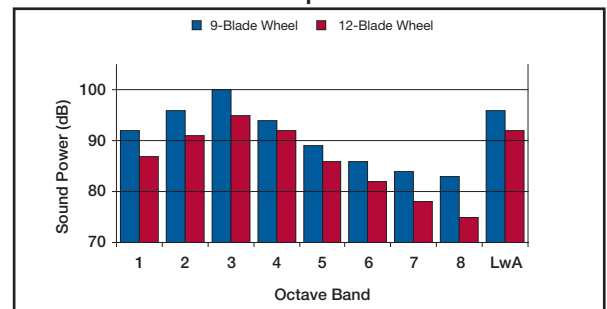

Figure 2

Outlet Sound Comparison - Size 33

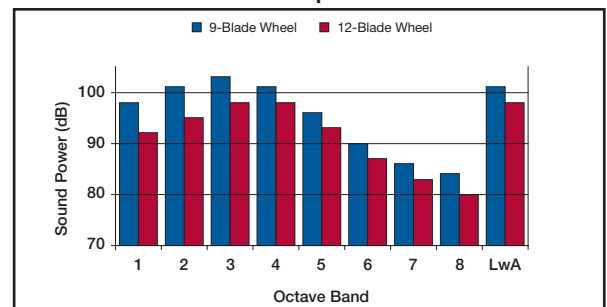
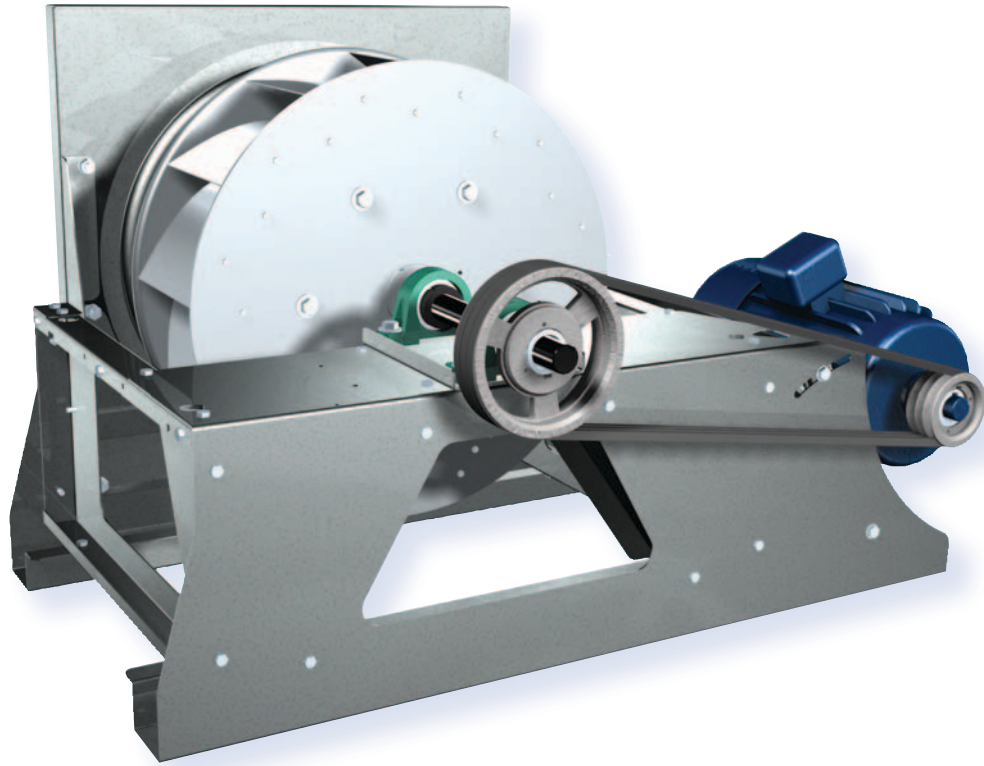
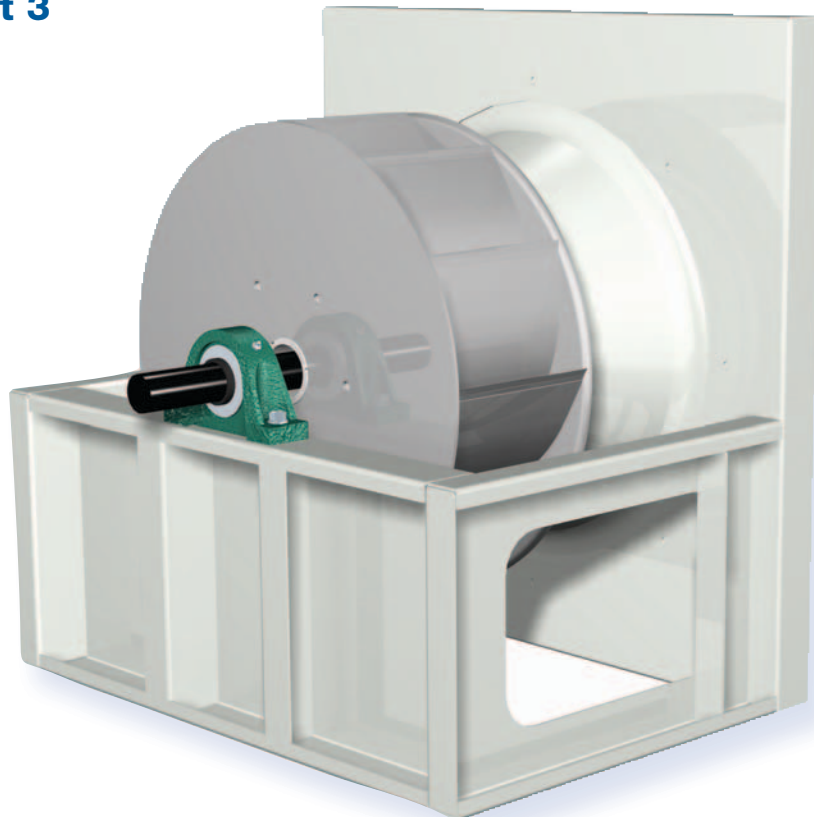

Figure 3

QEM Arrangement 9 Motor on Right



QEP Arrangement 3



12-Blade Aluminum Airfoil Wheel

Both the QEM and QEP plenums feature the same high efficiency and low sound 12-blade airfoil design. The aluminum wheel reduces start-up torque requirements as well as shaft loading during operation. Blades for sizes 12-48 are constructed of 6063-T5 aluminum extrusions while sizes 54-73 utilize precision laser cut and die formed 5052 aluminum blades to improve efficiency and reduce vibration. All wheels are balanced to grade G6.3 per ANSI S2.19.

AMCA Air and Sound Certification

AMCA certification assures that all Greenheck plenum fans will perform as cataloged. Fans are rated for air performance as well as sound levels (inlet and outlet).

Quality Assurance

All plenum fans receive a run test at the design speed in the factory after final assembly. QEM fans are checked for amp draw and the levels recorded. QEP fans are subjected to a complete vibration analysis in three planes. The recorded filter-in vibration levels must meet the requirements of BV-3 AMCA/ANSI standard 204-05 (Balance Quality and Vibration Levels for Fans). A permanent record of this test is kept on file at the factory for future reference. A copy of the test report is available upon request.

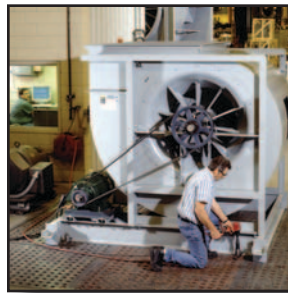

Premium Quality Bearings

Belt drive plenum fans are supplied with air handling quality bearings which are 100% inspected to be within tolerance for swivel torque, noise levels and bore size specifications. Other bearing design features include concentric mounting collars (no set screws) which provide superior grip force between the collar and the fan shaft as well as zerk fittings for lubrication.



	QEM	QEP
Available Sizes	11 sizes 12-36	18 sizes 12-73
Maximum Volume	35,000 cfm 17 m ³ /s	200,000 cfm 99 m ³ /s
Maximum Pressure	6.5 in. wg 1.6 kPa	12 in. wg 3 kPa
Performance Classes	I, II (Partial)	I, II, III
Arrangements	4, 9	1, 3, 4
Mounting	Horizontal	Horizontal, Vertical
Wheel, 12-Blade Aluminum	Standard	Standard
AMCA Air	Standard	Standard
AMCA Sound	Standard	Standard
Wheel Balance	G 6.3	G 6.3
Recorded Vibration Signature	No	Standard
Bearings, Life Ratings		
L ₁₀ 50,000 hrs = L ₅₀ 250,000 hrs	Standard	N/A
L ₁₀ 80,000 hrs = L ₅₀ 400,000 hrs	N/A	Standard
Framework Construction		
Galvanized Steel	Standard	N/A
Permatector™ Coated Steel	N/A	Standard
Integral Lifting Points	Standard	Standard

Drive Frame

All plenum fans feature a laser cut and formed framework. Model QEM utilizes a galvanized construction, while the QEP features a fully welded design with Permatector™, an electrostatically applied polyester urethane powder coat finish.

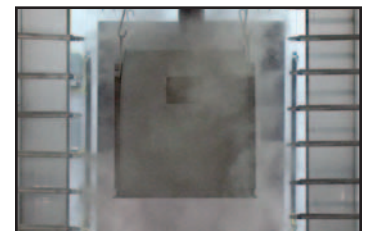

Fan Shaft

Shafting through 2 in. (508mm) diameter is AISI 1018 steel. Larger shafts are AISI 1045 steel. All shafting is turned, ground, polished and sized such that the first critical speed is 200% of the maximum operating speed for increased bearing life and decreased vibration.

CAD Drawings Available

To assist with system design and layout, 2D CAD files for all plenum fans are available. Drawings can be downloaded directly through the CAPS program after product selection at www.greenheck.com or consult the factory.

QEM

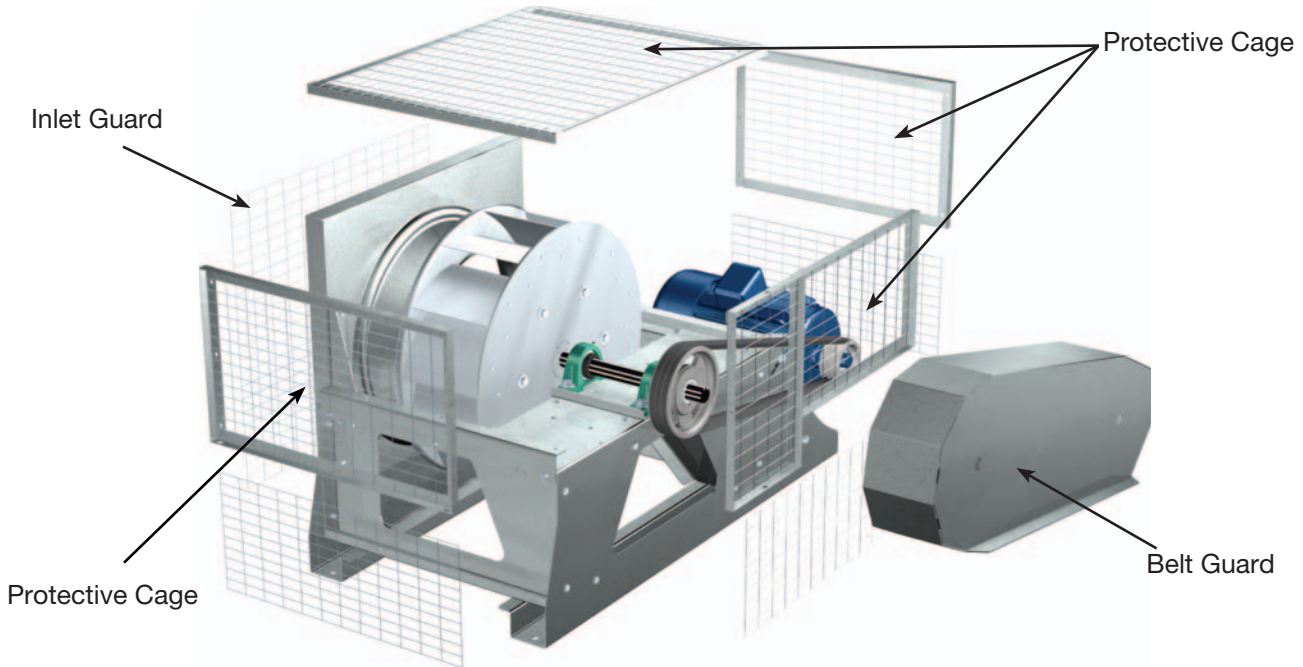

QEP

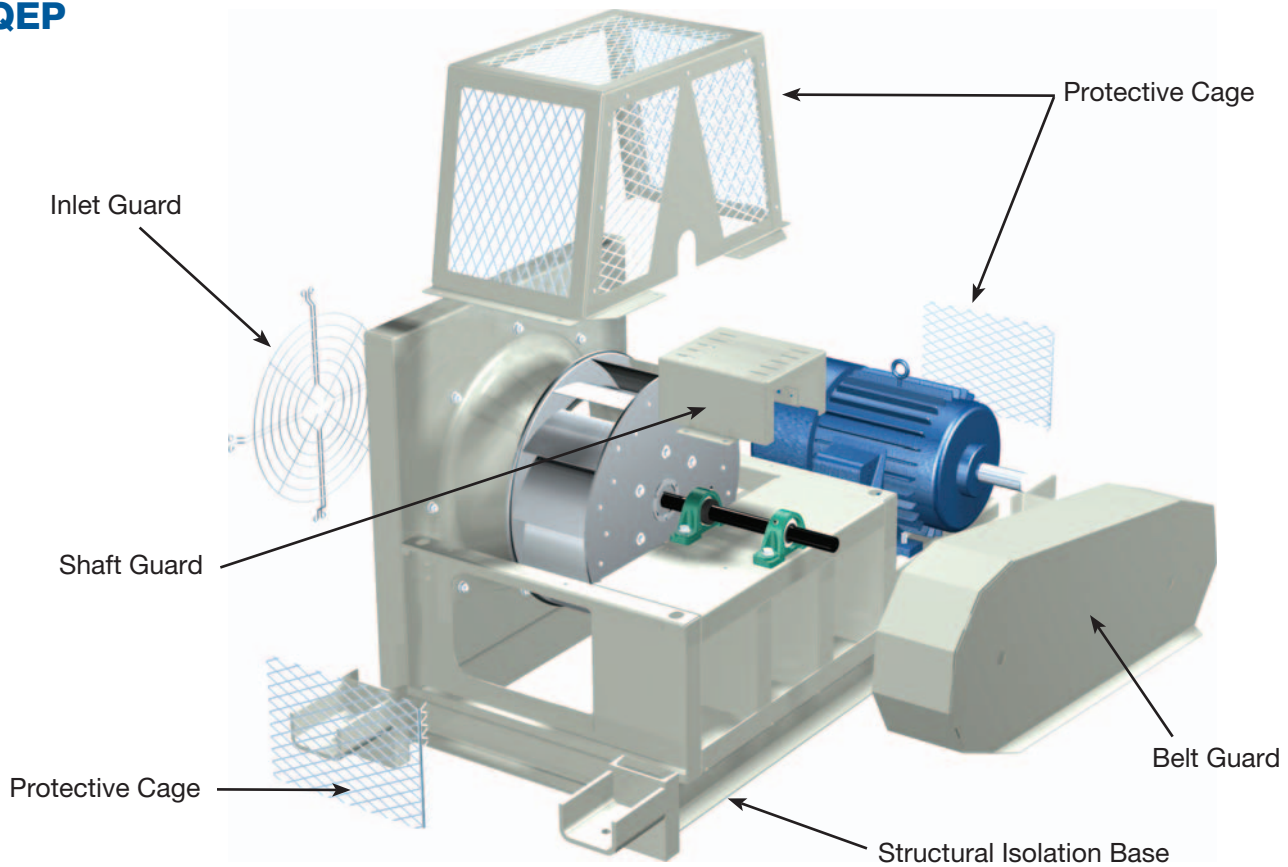

Inlet Guard

Assembled and mounted low-pressure loss, zinc coated guards.

Belt Guard

Custom guarding with two tachometer holes and belt tension inspection door, assembled and mounted.

Protective Cage

Totally enclosed guard to protect personnel from unshoused spinning wheel. Typically packaged with a belt guard to provide complete protection. (arrangement 1 QEP also requires a shaft guard).

Shaft Guard

Formed guard that covers the shaft between the belt guard and the plenum cage (arrangement 1 only).

Extended Lube Lines

Allows for bearing lubrication from a remote location. Ideal for guarded fans or for relocating all lubrication requirements to a single, readily accessible location.

Factory Selected Drives

Cast iron sheaves and matched belts standard with a 1.5 drive service factor. Installed and aligned to provide reduced vibration levels and minimize installation costs.

Motor for use with Frequency Drive

Motors meet EPACT or NEMA Premium efficiencies and are available in VFD compatible construction.

Disconnect Switch

Toggle type and heavy duty disconnect switches are available for positive electrical shutoff and safety when servicing fans.

Sure-Aire™ Flow Measurement

Sure-Aire™ provides the real-time flow measurement for use in building automation systems. The Sure-Aire's non-invasive design is accurate to within 3% and does not impact fan performance.

Isolators

Base mount isolators are available in either neoprene or spring mounts. The isolators are sized to match the fan weight at each mounting point.

Isolation Base (QEP)

Provides a known space envelope for the complete fan assembly. Compact C-channel platform welded for superior rigidity and solid foundation.

	QEM	QEP
Bearings, Extended Life		
L ₁₀ 200,000 hrs = L ₅₀ 1,000,000 hrs	N/A	Optional
Isolation		
Direct Mount Isolators	Optional	Optional
Structural Base w/ Isolators	N/A	Optional
OSHA Compliant Guarding		
Guard, Inlet	Optional	Optional
Guard, Belt	Optional	Optional
Guard, Shaft	Guard	Optional
Protective Cage	Package	Optional
Extended Lube Lines	Optional	Optional
Sure-Aire™ Flow Monitor	Optional	Optional
Inlet Vane Damper, Nested	N/A	Optional
Inlet Collar	N/A	Optional
Flange, Inlet	N/A	Optional
Special Powder Coatings	N/A	Optional

Extended Life Bearings (QEP)

Air handling quality, pillow block bearings meet a basic rating fatigue life L₁₀, per ABMA standards, in excess of 200,000 hours at maximum operating speed. Equivalent to average or L₅₀ life of 1,000,000 hours.

Inlet Vane Damper (QEP)

Built into the inlet cone and allows for continuous modulation of airflow or one-time system balance at start-up.

Inlet Collar (QEP)

Welded to the fan inlet panel (arrangement 3) or inlet cone (arrangement 1 and 4) to allow for round slip-fit connections to the fan inlet.

Inlet Flange (QEP)

Circular inlet flanges with pre-punched holes provide an easy means for bolted connection to ductwork. Requires an inlet collar. Matching bolt-on companion flanges are also available.

Special Coatings (QEP)

Special coatings are available for protective purposes. Coatings are applied before assembly so that each manufactured component is coated inside and out. Consult Greenheck's Product Application Guide, Performance Coatings for Ventilation Products for a complete listing of coatings and a relative resistance chart.

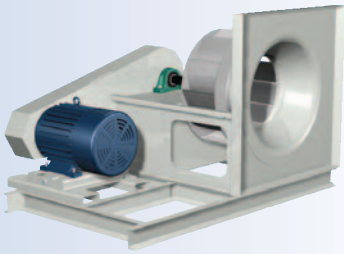

QEP Arrangement 1 – Horizontal, Motor on Base Sizes 12–73

(shown with optional base & belt guard)

- No bearings in the fan inlet to effect performance
- Requires separate structural base for motor mounting
- Motor frame size does not limit availability

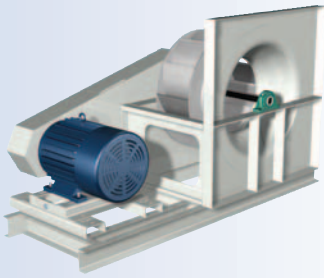

QEP Arrangement 3 – Horizontal, Motor on Base Sizes 18–73

(shown with optional base & belt guard)

- Reduced length due to bearing located in the inlet
- Requires separate structural base for motor mounting
- Motor frame size does not limit availability



QEP Arrangement 3 – Horizontal, Motor on Frame (Side) Sizes 12–73

- Compact design with motor mounted to side of fan
- Used in installations with tight spaces and lower overhead clearance
- No separate base required for mounting motor
- Limited availability based on motor frame size
- Motor slide base provides for convenient belt tightening

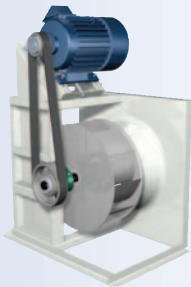

QEP Arrangement 3 – Horizontal, Motor on Frame (Top) Sizes 12–73

- Compact design with motor mounted to top of fan
- No separate base required for mounting motor
- Limited availability based on motor frame size
- Motor slide base provides for convenient belt tightening

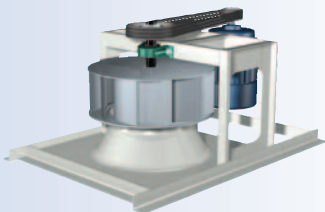

QEP Arrangement 3 – Vertical, Motor on Frame Sizes 12–54

- Compact design with motor mounted to side of fan
- No separate structural base required for mounting motor
- Limited availability based on motor frame size
- Motor slide base provides for convenient belt tightening

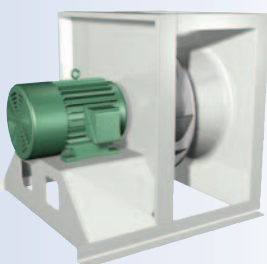

QEP Arrangement 4 – Horizontal, Direct Drive Sizes 15–60

- Minimal maintenance with no belts or pulleys
- Low vibration levels
- Compact, space saving design with motor directly connected to wheel
- Different performances through wheel width and motor rpm variations
- Elimination of belt residue that can contaminate the airstream



QEM Arrangement 9 – Horizontal, Motor on Frame (Side) Sizes 12–36

- Compact design with motor mounted to side of fan
- Used in installations with tight spaces and lower overhead clearance
- No separate base required for mounting motor
- Motor slide base provides for convenient belt tightening

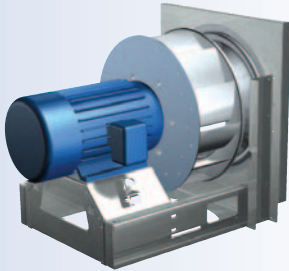

QEM Arrangement 4 – Horizontal, Direct Drive Sizes 15–36

- Minimal maintenance with no belts and pulleys
- Low vibration levels
- Compact, space saving design with motor directly connected to wheel
- Different performance through wheel width and motor rpm variations
- Elimination of belt residue that can contaminate the airstream

Available Motor on Frame Positions

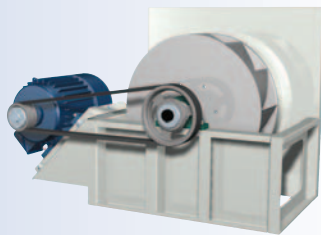

Left



Top

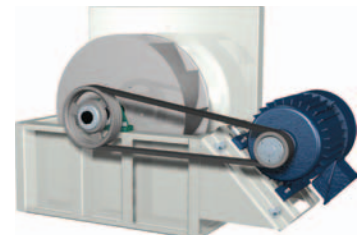

Right

Available Motor on Base Positions

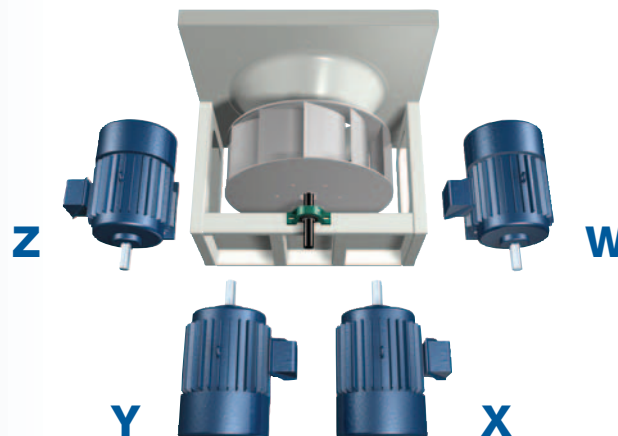

Air Plenum Design Guidelines

To assure optimum performance and be able to use the system effect coefficients below, the following guidelines should be adhered to in the plenum design:

1. Flexible connections at the inlet are recommended to isolate vibration. The inlet connection can be square (connected to the inlet panel) or round (connected to an optional inlet collar).
2. Plenum walls should be at least one-half of a wheel diameter away from the fan.
3. Dampers or coils should be at least three-quarters of a wheel diameter away from the fan to assure an even velocity distribution through them.
4. For fans operating in parallel:

Have one wheel diameter clearance between adjacent fans.

Backstop clutches or backflow control dampers should be used to prevent windmilling of wheels if fans are started or stopped at different times.

Do not select fans near the top of the fan curve to prevent unstable operation.

Wheels should be selected as contra-rotating (CW - CCW - CW etc.) to improve airflow patterns between the fans.

See AMCA Publication 201 for additional information on this subject.

Duct System Effect

Reduction in cataloged air performance due to a plenum around the fan is called a system effect. System effect is a pressure loss, which must be added to the total external static pressure of the duct system in order to make the proper fan selection from catalog data. The pressure loss calculation is based on the velocity of the air in the discharge ductwork. As shown below, it is derived by multiplying the appropriate coefficient by the velocity pressure.

Discharge Configuration Coefficients		
Discharge	Radial	Axial
 Unducted	2.0	2.3
 Ducted	1.5	1.8
 Ducted with Bell	1.1	1.4

TABLE 1: Discharge Coefficients

Effects of Air Density

Ratings in the fan performance tables and curves of this catalog are based on standard air: clean and dry with a density of 0.075 lbs/ft³ at 70°F at a pressure of 29.92 in. of mercury. A change in elevation, temperature or the type of gas handled will affect density. A fan running at a constant speed and installed in a fixed system will experience changes in pressure output and horsepower consumption if the density of the airstream varies. The air volume delivered by the fan will remain constant regardless of air density.

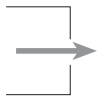
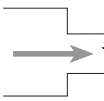
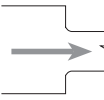
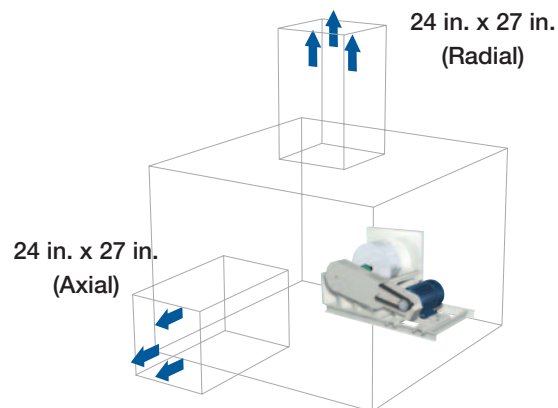

Example of Performance Correction

Select a fan to meet the following requirements:

- Volume: 20,000 cfm
- Static Pressure: 2.156 in. wg
- Airstream Temperature: 70°F
- Installation Elevation: 13,000 ft.
- Plenum Discharges (ducted): 24 in. x 27 in. Radial
24 in. x 27 in. Axial

1. The selection is at non-standard atmospheric conditions and must be corrected to standard conditions to use cataloged data. Volume remains at 20,000 cfm, since the volume delivered is not affected by air density.

2. An air density correction factor must be applied to the static pressure. For an elevation of 13,000 ft. and a temperature of 70°F, 1.6 is the required correction factor (Table 2A). Use the correction factor to adjust the static pressure by multiplying the required static pressure by the correction factor.

$$2.156 \text{ in. wg} \times 1.6 = 3.45 \text{ in. wg}$$

3. System effects for plenum discharges must also be calculated and added to the design pressure. In a properly designed plenum (see Duct System Effect section), the system effect coefficient (C_o) depends on the orientation of the discharge relative to the fan and duct connection (if any). For air plenums with multiple discharges, calculate the system effect by using the highest loss coefficient for all discharges. In this example, the discharges are ducted so the highest loss will be axial ($C_o = 1.8$). Assume that the two discharges will each handle 10,000 cfm.

Plenum Exit Velocity [ft/min]
 = Volume [ft³/min] / Outlet Area [ft²]
 = 10,000 [ft³/min] / (24 in. x 27 in. / 144 [in²/ft²])
 = 2,222 [ft/min]

System Effect
 = ($C_o \times \text{Density [lb/ft}^3\text{]} \times$
 (Exit Velocity [ft/min] / 1096)²
 = 1.8 x 0.075 x (2,222 / 1096)² = 0.55

4. Now select a fan size from the catalog data based on the corrected performance. The corrected static pressure of 3.45 in. wg plus the system effect of 0.55 in. wg means the fan should be selected for 20,000 cfm at 4.0 in. wg. A size 33 plenum will meet this performance at 1290 frpm using 17.9 bhp. (Note: The bhp does not include drive losses. Consult AMCA Publication 203-90 for help in estimating drive losses.) Based on the required frpm, the user has the option of selecting either model QEM or QEP.

Airstream Temperature Variations

When a fan is selected, two temperatures in the airstream should be considered: Start-up and normal operation. While the hp required is reduced at higher temperatures, the motor must be sized based the lowest temperature that could be present in the airstream (when air density is at its maximum value).

Reconsider the example assuming that the fan was operating at 9,000 ft. elevation with a start-up airstream temperature of -25°F and a normal operating temperature of 150°F. (Note the new normal operating conditions require the same density correction factor as 13,000 ft. elevation at 70°F, so the fan selection is still valid.)

First, calculate hp at the start-up condition. For -25°F at 9,000 ft. elevation, the air density correction factor (Table 2A) is 1.14. Divide the cataloged bhp by the correction factor.

17.9 ÷ 1.14 = 15.7 bhp at start-up

Now calculate hp during normal operation using the same procedure, but for 150°F at 9,000 ft. elevation.

17.9 ÷ 1.60 = 11.2 bhp during normal operation.

The motor should be sized based on the larger of these two values. So although the normal operation would only require a 15 hp motor, the fan should be selected with a 20 hp motor based on the higher hp requirement at start-up.

		ELEVATION (FEET ABOVE SEA LEVEL)													
		0	1000	2000	3000	4000	5000	6000	7000	8000	9000	10000	11000	12000	13000
AIRSTREAM TEMPERATURE (°F)	-50	0.77	0.80	0.83	0.86	0.89	0.93	0.96	1.00	1.03	1.07	1.11	1.15	1.20	1.24
	-25	0.82	0.85	0.88	0.92	0.95	0.98	1.02	1.06	1.10	1.14	1.18	1.22	1.27	1.32
	0	0.87	0.90	0.93	0.97	1.00	1.04	1.08	1.12	1.16	1.20	1.25	1.29	1.34	1.39
	50	0.96	1.00	1.03	1.07	1.11	1.15	1.20	1.24	1.29	1.33	1.38	1.44	1.49	1.54
	70	1.00	1.04	1.08	1.12	1.16	1.20	1.24	1.29	1.34	1.39	1.44	1.49	1.55	1.60
	100	1.06	1.10	1.14	1.18	1.22	1.27	1.31	1.36	1.41	1.47	1.52	1.58	1.63	1.69
	150	1.15	1.19	1.24	1.28	1.33	1.38	1.43	1.48	1.54	1.60	1.66	1.72	1.78	1.85
	200	1.25	1.29	1.34	1.39	1.44	1.49	1.55	1.61	1.67	1.73	1.79	1.86	1.93	2.00
	250	1.34	1.39	1.44	1.49	1.55	1.61	1.67	1.73	1.79	1.86	1.93	2.00	2.07	2.15
	300	1.43	1.49	1.54	1.60	1.66	1.72	1.78	1.85	1.92	1.99	2.06	2.14	2.22	2.30
	350	1.53	1.58	1.64	1.70	1.77	1.83	1.90	1.97	2.04	2.12	2.20	2.28	2.36	2.45
	400	1.62	1.68	1.74	1.81	1.88	1.95	2.02	2.09	2.17	2.25	2.33	2.42	2.51	2.60
	450	1.72	1.78	1.85	1.91	1.99	2.06	2.14	2.21	2.30	2.38	2.47	2.56	2.66	2.75
	500	1.81	1.88	1.95	2.02	2.09	2.17	2.25	2.34	2.42	2.51	2.60	2.70	2.80	2.90
	550	1.91	1.98	2.05	2.13	2.20	2.29	2.37	2.46	2.55	2.64	2.74	2.84	2.95	3.06
	600	2.00	2.07	2.15	2.23	2.31	2.40	2.49	2.58	2.67	2.77	2.88	2.98	3.09	3.21
650	2.09	2.17	2.25	2.34	2.42	2.51	2.60	2.70	2.80	2.90	3.01	3.12	3.24	3.36	
700	2.19	2.27	2.35	2.44	2.53	2.62	2.72	2.82	2.93	3.04	3.15	3.26	3.38	3.51	
750	2.28	2.37	2.46	2.55	2.64	2.74	2.84	2.94	3.05	3.17	3.28	3.40	3.53	3.66	
800	2.38	2.47	2.56	2.65	2.75	2.85	2.96	3.07	3.18	3.30	3.42	3.55	3.68	3.81	
850	2.47	2.56	2.66	2.76	2.86	2.96	3.07	3.19	3.31	3.43	3.55	3.69	3.82	3.96	
900	2.57	2.66	2.76	2.86	2.97	3.08	3.19	3.31	3.43	3.56	3.69	3.83	3.97	4.12	
950	2.66	2.76	2.86	2.97	3.08	3.19	3.31	3.43	3.56	3.69	3.83	3.97	4.11	4.27	
1000	2.75	2.86	2.96	3.07	3.19	3.30	3.43	3.55	3.68	3.82	3.96	4.11	4.26	4.42	

TABLE 2A: Density Correction Factors (Imperial Units)

		ELEVATION (METERS ABOVE SEA LEVEL)													
		0	250	500	750	1000	1250	1500	1750	2000	2250	2500	2750	3000	3500
AIRSTREAM TEMPERATURE (°C)	-50	0.76	0.78	0.81	0.83	0.85	0.88	0.91	0.93	0.96	0.99	1.02	1.05	1.08	1.15
	-25	0.84	0.87	0.90	0.92	0.95	0.98	1.01	1.04	1.07	1.10	1.14	1.17	1.21	1.28
	0	0.93	0.96	0.99	1.02	1.05	1.08	1.11	1.14	1.18	1.21	1.25	1.29	1.33	1.41
	21	1.00	1.03	1.06	1.09	1.13	1.16	1.20	1.23	1.27	1.31	1.35	1.39	1.43	1.52
	50	1.10	1.13	1.17	1.20	1.24	1.27	1.31	1.35	1.39	1.44	1.48	1.52	1.57	1.67
	75	1.18	1.22	1.26	1.29	1.33	1.37	1.41	1.46	1.50	1.55	1.59	1.64	1.69	1.80
	100	1.27	1.31	1.35	1.39	1.43	1.47	1.52	1.56	1.61	1.66	1.71	1.76	1.81	1.92
	125	1.35	1.39	1.44	1.48	1.52	1.57	1.62	1.67	1.72	1.77	1.82	1.88	1.93	2.05
	150	1.44	1.48	1.53	1.57	1.62	1.67	1.72	1.77	1.82	1.88	1.94	2.00	2.06	2.18
	175	1.52	1.57	1.62	1.67	1.72	1.77	1.82	1.88	1.93	1.99	2.05	2.11	2.18	2.31
	200	1.61	1.66	1.71	1.76	1.81	1.87	1.92	1.98	2.04	2.10	2.17	2.23	2.30	2.44
	225	1.69	1.74	1.80	1.85	1.91	1.96	2.02	2.09	2.15	2.21	2.28	2.35	2.42	2.57
	250	1.78	1.83	1.89	1.94	2.00	2.06	2.13	2.19	2.26	2.32	2.39	2.47	2.54	2.70
	275	1.86	1.92	1.98	2.04	2.10	2.16	2.23	2.29	2.36	2.44	2.51	2.58	2.66	2.83
	300	1.95	2.01	2.07	2.13	2.19	2.26	2.33	2.40	2.47	2.55	2.62	2.70	2.78	2.96
	325	2.03	2.09	2.16	2.22	2.29	2.36	2.43	2.50	2.58	2.66	2.74	2.82	2.91	3.08
350	2.12	2.18	2.25	2.31	2.38	2.46	2.53	2.61	2.69	2.77	2.85	2.94	3.03	3.21	
375	2.20	2.27	2.34	2.41	2.48	2.56	2.63	2.71	2.79	2.88	2.97	3.06	3.15	3.34	
400	2.29	2.36	2.43	2.50	2.58	2.65	2.73	2.82	2.90	2.99	3.08	3.17	3.27	3.47	
425	2.37	2.44	2.52	2.59	2.67	2.75	2.84	2.92	3.01	3.10	3.20	3.29	3.39	3.60	
450	2.46	2.53	2.61	2.69	2.77	2.85	2.94	3.03	3.12	3.21	3.31	3.41	3.51	3.73	
475	2.54	2.62	2.70	2.78	2.86	2.95	3.04	3.13	3.23	3.32	3.42	3.53	3.63	3.86	
500	2.63	2.71	2.79	2.87	2.96	3.05	3.14	3.24	3.33	3.43	3.54	3.65	3.76	3.99	
550	2.80	2.88	2.97	3.06	3.15	3.25	3.34	3.44	3.55	3.66	3.77	3.88	4.00	4.24	

TABLE 2B: Density Correction Factors (Metric Units)

Direct drive construction offers many advantages for commercial or industrial air handling applications.

- Reduced maintenance (no belts and shaft bearings to service)
- Compact housing design requires a smaller footprint
- Low vibration
- Suitable for clean air application (no belt or bearing residue in airstream)

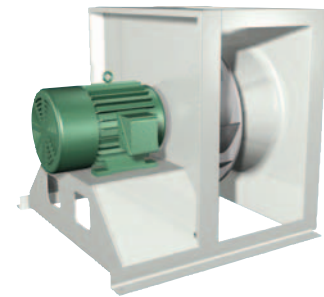

**QEP Arrangement 4
Horizontal, Direct Drive**

Flow Control Options

Direct drive models require a variable frequency drive (VFD) or a partial wheel to assist in matching actual fan performance to the desired point of operation. A VFD allows the fan performance to be adjusted to assist in system balancing and provides flexibility in adapting to future system changes. VFDs in conjunction with a QEM or QEP can assist in reducing energy consumption. Partial wheel widths can also be used to attain a specific fan performance. Partial wheel widths are available in 5% increments ranging from 50%–100%.

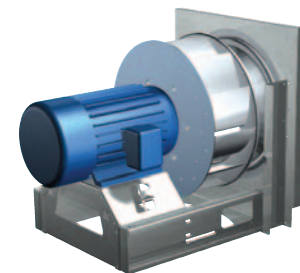

**QEM Arrangement 4
Horizontal, Direct Drive**

The charts on these pages allow for a quick estimation of the required fan size and motor speed to achieve the desired point of operation. Colored bands for a given size in each chart show the acceptable performance range for the most commonly selected fan sizes at a given motor speed. For detailed selection information, please consult our Computer Aided Product Selection (CAPS) software.

1425 RPM (50 Hz)

Model QEM
Sizes 15–36

Model QEP
Sizes 15–40

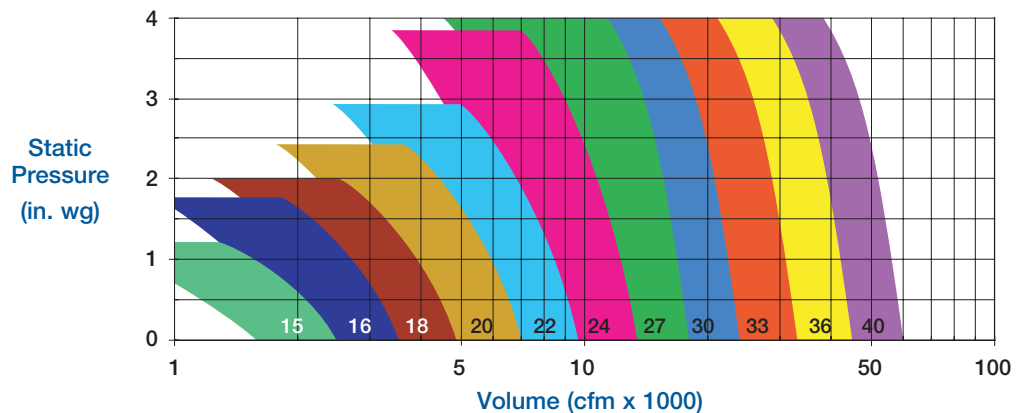

950 RPM (50 Hz)

Model QEM
Sizes 15–36

Model QEP
Sizes 15–60

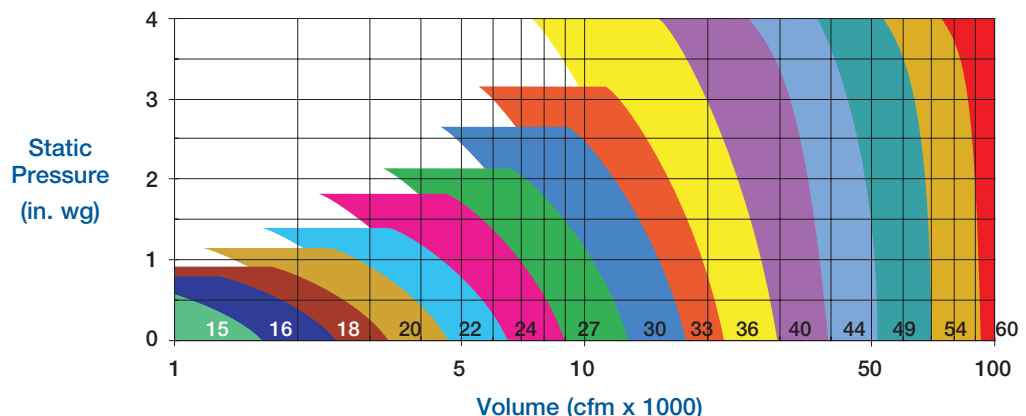

1770 RPM (60 Hz)

Model QEM
Sizes 15–22

Model QEP
Sizes 15–33

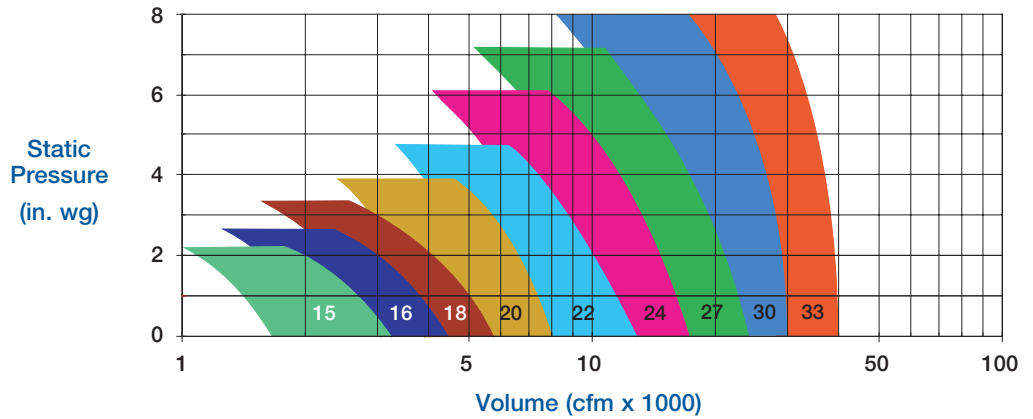

1170 RPM (60 Hz)

Model QEM
Sizes 15–36

Model QEP
Sizes 15–54

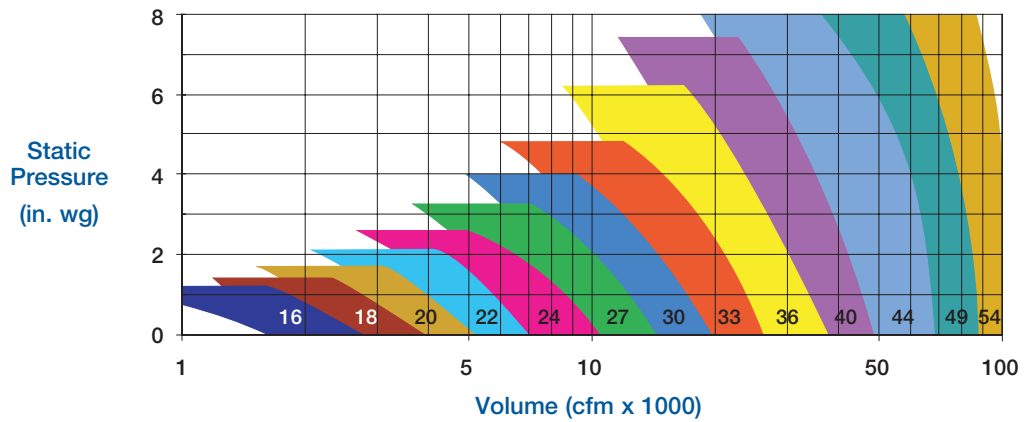

870 RPM (60 Hz)

Model QEM
Sizes 24–36

Model QEP
Sizes 22–60

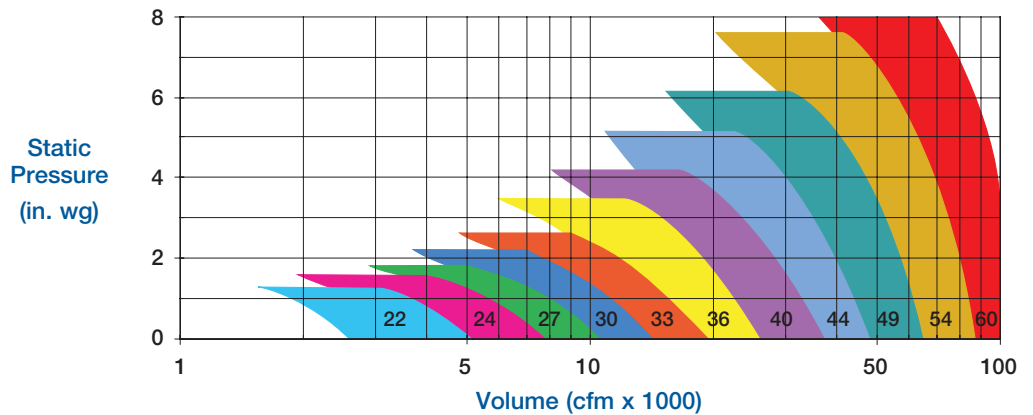

690 RPM (60 Hz)

Model QEP
Sizes 27–60

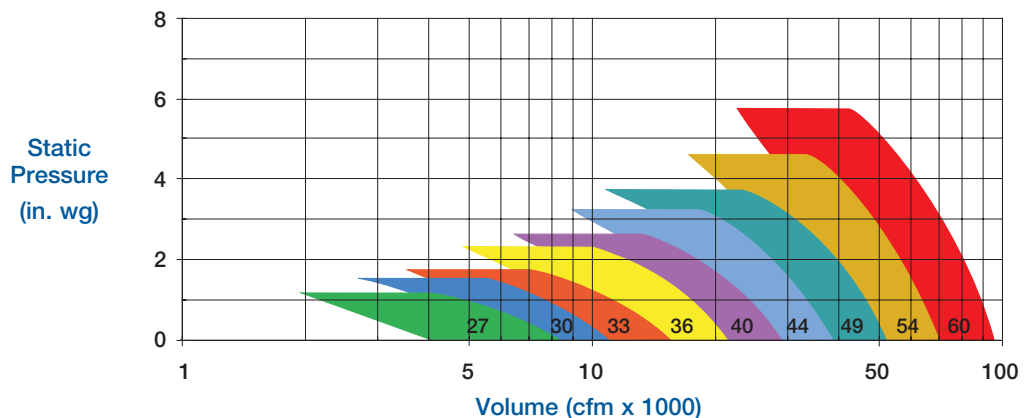

Plenum Size 12

QEP Class I	Maximum rpm 2991
QEP Class II	Maximum rpm 3064
QEM █	Maximum rpm 3510

Note: Model QEM does not utilize class designations.

QEP Motor on Frame Limit	184T
Minimum Motor Size	1/3 [hp]
Wheel Diameter	15.00 [in.] 381 [mm]
Peak Power	(rpm / 2097) ³ [hp] (rpm / 2312) ³ [kW]
Wheel Outlet Velocity	cfm / 1.12 [ft/min] m ³ /s / 0.66 [m/s]
Tip Speed	rpm x 3.93 [ft/min] rpm x 0.0199 [m/s]
% Wide Open Volume (%WOV)	cfm / (rpm x 0.0126) [%] m ³ /hr / (rpm x 0.0214) [%]

Imperial data — Metric data

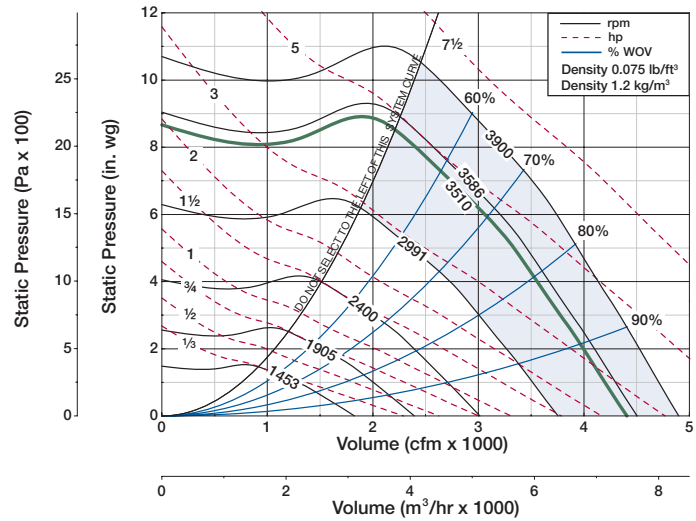

CFM	OV	STATIC PRESSURE (in. wg)																		
		1		2		3		4		5		6		7		8		9		
		RPM	BHP	RPM	BHP	RPM	BHP	RPM	BHP	RPM	BHP	RPM	BHP	RPM	BHP	RPM	BHP	RPM	BHP	
2100	1875	1971	0.64	2213	1.05	2449	1.52	2668	2.01	2865	2.54	3049	3.07	3222	3.61					
2200	1964	2040	0.69	2277	1.12	2503	1.60	2716	2.11	2912	2.65	3093	3.20	3264	3.76	3425	4.34			
2300	2053	2109	0.75	2342	1.19	2558	1.68	2765	2.21	2960	2.76	3139	3.33	3307	3.92	3467	4.51	3619	5.11	
2400	2142	2178	0.81	2407	1.27	2614	1.77	2814	2.32	3008	2.88	3186	3.46	3351	4.08	3510	4.68	3661	5.30	
2500	2232	2248	0.88	2473	1.35	2670	1.86	2869	2.42	3056	3.00	3233	3.60	3398	4.22	3554	4.86	3704	5.49	
2600	2321	2319	0.95	2539	1.44	2728	1.95	2923	2.53	3105	3.13	3281	3.74	3445	4.38	3598	5.04	3747	5.69	
2700	2410	2391	1.03	2606	1.53	2793	2.06	2979	2.64	3156	3.26	3329	3.89	3492	4.54	3645	5.21	3790	5.90	
2800	2500	2464	1.11	2673	1.63	2858	2.17	3034	2.75	3210	3.39	3378	4.04	3540	4.70	3692	5.39	3836	6.09	
2900	2589	2537	1.19	2741	1.73	2923	2.28	3091	2.87	3265	3.52	3427	4.19	3588	4.87	3740	5.57	3883	6.29	
3000	2678	2610	1.28	2809	1.83	2988	2.40	3149	3.00	3320	3.66	3480	4.35	3637	5.04	3788	5.76			
3100	2767	2684	1.38	2877	1.94	3054	2.53	3213	3.14	3375	3.80	3534	4.50	3686	5.23	3836	5.95			
3200	2857	2758	1.48	2946	2.06	3121	2.66	3278	3.29	3432	3.95	3589	4.67	3737	5.41	3885	6.15			

RPM	% WOV	Inlet Sound Power, L _{wi} [dB ref 10 ⁻¹² watts]								
		1	2	3	4	5	6	7	8	L _{wi} A
1200	100	76	70	73	66	62	62	58	47	70
	80	75	68	68	63	61	60	54	45	67
	60	77	69	72	63	57	55	53	46	67
	50	77	69	74	63	56	55	54	47	68
1600	100	82	72	74	72	67	65	64	56	74
	80	77	71	73	70	64	64	61	53	72
	60	75	69	73	70	62	61	59	54	71
	50	75	70	74	70	62	60	60	55	71
2200	100	86	77	74	84	74	73	71	70	83
	80	86	78	74	85	71	71	69	64	83
	60	84	77	75	82	70	70	67	64	81
	50	85	77	79	81	70	68	67	64	80
2900	100	80	82	80	86	79	79	78	78	87
	80	77	81	79	89	77	78	77	74	88
	60	76	79	79	87	77	77	75	71	86
	50	77	79	80	88	77	75	74	72	86
3900	100	86	90	89	90	90	85	85	84	94
	80	82	88	88	92	91	84	84	81	94
	60	81	86	87	91	89	83	82	79	93
	50	82	87	88	91	90	82	81	80	94

RPM	% WOV	Outlet Sound Power, L _{wo} [dB ref 10 ⁻¹² watts]								
		1	2	3	4	5	6	7	8	L _{wo} A
1200	100	72	67	73	67	66	65	64	54	72
	80	71	66	71	66	65	65	61	53	71
	60	70	67	70	66	64	65	61	54	71
	50	70	67	70	66	63	65	60	54	71
1600	100	78	70	74	73	72	71	69	63	78
	80	77	69	74	72	70	69	68	61	76
	60	77	69	72	74	68	69	66	61	76
	50	78	70	75	73	68	68	66	62	76
2200	100	79	72	75	80	80	79	78	75	85
	80	83	73	74	79	77	77	74	71	83
	60	83	73	74	79	76	76	73	70	82
	50	81	74	78	78	76	75	72	70	82
2900	100	87	81	80	86	85	85	84	84	91
	80	88	82	81	85	82	82	82	79	89
	60	90	81	82	85	82	81	81	77	88
	50	91	83	82	87	82	81	79	77	89
3900	100	92	92	89	90	93	91	91	90	98
	80	93	94	89	91	91	89	88	87	96
	60	96	94	89	91	91	88	88	85	96
	50	96	95	90	92	92	88	87	84	96

Performance certified is for installation type A: Free inlet, Free outlet. Power ratings (Bhp) do not include transmission losses. Performance ratings do not include the effects of appurtenances (accessories).

The sound power level ratings shown are in decibels, referred to 10⁻¹² watts calculated per AMCA International Standard 301. Values shown are for inlet L_{wi}, L_{wi}A and outlet L_{wo}, L_{wo}A sound power levels for installation type A: Free inlet, Free outlet. The A-weighted sound ratings shown have been calculated per AMCA International Standard 301. Outlet ratings do not include the effects of duct end correction.

The AMCA International Certified Ratings Seal for Sound for model QEM only applies to the single L_{wi}A and L_{wo}A values.

Plenum Size 15

QEP Class I	Maximum rpm 2611
QEP Class II	Maximum rpm 3404
QEP Class III	Maximum rpm 4000
QEM	Maximum rpm 3064

Note: Model QEM does not utilize class designations.

QEP Motor on Frame Limit	213T
Minimum Motor Size	1/3 [hp]
Wheel Diameter	15.00 [in.] 381 [mm]
Peak Power	(rpm / 1842) ³ [hp] (rpm / 2031) ³ [kW]
Wheel Outlet Velocity	cfm / 1.71 [ft/min] m ³ /s / 1.01 [m/s]
Tip Speed	rpm x 3.93 [ft/min] rpm x 0.0199 [m/s]
% Wide Open Volume (%WOV)	cfm / (rpm x 0.0186) [%] m ³ /hr / (rpm x 0.0316) [%]

Imperial data — Metric data

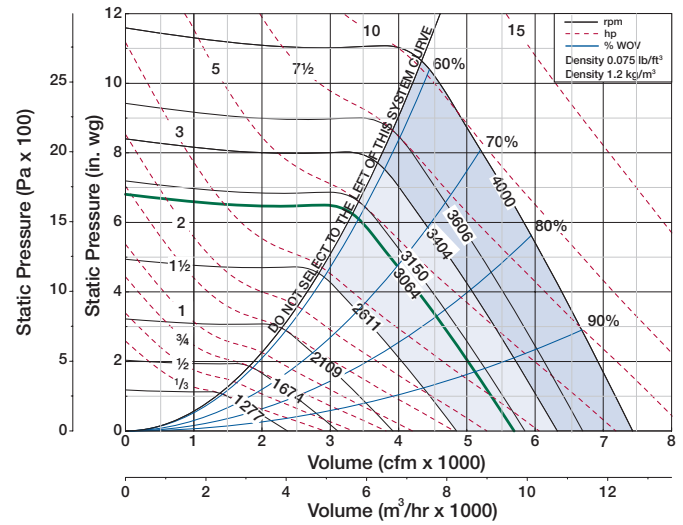

CFM	OV	STATIC PRESSURE (in. wg)																	
		1		2		3		4		5		6		7		8		9	
		RPM	BHP	RPM	BHP	RPM	BHP	RPM	BHP	RPM	BHP	RPM	BHP	RPM	BHP	RPM	BHP	RPM	BHP
3000	1744	1910	0.90	2154	1.46	2371	2.05	2570	2.67	2750	3.33								
3200	1860	2002	1.01	2238	1.61	2448	2.22	2641	2.87	2819	3.55								
3400	1976	2096	1.13	2324	1.76	2528	2.41	2713	3.09	2889	3.79	3051	4.52						
3600	2093	2191	1.27	2411	1.92	2608	2.61	2790	3.31	2961	4.04	3121	4.80	3271	5.59				
3800	2209	2287	1.41	2500	2.10	2691	2.82	2869	3.55	3033	4.31	3192	5.09	3340	5.90	3480	6.74		
4000	2325	2385	1.56	2590	2.29	2776	3.04	2949	3.81	3110	4.59	3264	5.40	3411	6.24	3549	7.10	3681	7.98
4200	2441	2483	1.73	2681	2.49	2862	3.27	3029	4.08	3188	4.89	3337	5.73	3482	6.59	3619	7.47	3750	8.38
4400	2558	2582	1.91	2773	2.71	2949	3.52	3112	4.36	3268	5.20	3414	6.07	3554	6.96	3690	7.87	3820	8.80
4600	2674	2682	2.11	2867	2.94	3038	3.78	3197	4.65	3348	5.54	3492	6.43	3628	7.34	3762	8.28	3890	9.24
4800	2790	2782	2.32	2960	3.19	3127	4.06	3283	4.96	3429	5.89	3572	6.80	3706	7.75	3834	8.71	3962	9.69
5000	2906	2883	2.55	3055	3.45	3218	4.35	3370	5.28	3513	6.24	3652	7.20	3784	8.17	3911	9.16		
5200	3023	2984	2.79	3150	3.74	3309	4.66	3458	5.62	3599	6.61	3732	7.61	3864	8.61	3989	9.62		

RPM	% WOV	Inlet Sound Power, L _{Wi} [dB ref 10 ⁻¹² watts]									
		1	2	3	4	5	6	7	8	L _{WiA}	
1200	100	84	78	73	69	63	62	57	48	71	
	80	86	86	77	66	61	61	53	46	74	
	60	82	87	72	65	58	57	52	47	73	
	50	83	87	72	64	57	56	52	47	73	
1600	100	73	78	75	73	68	67	65	56	75	
	80	75	75	74	70	64	64	61	54	72	
	60	73	74	73	70	63	63	59	55	71	
	50	74	73	73	69	63	63	59	56	71	
2200	100	75	79	75	86	75	74	73	68	85	
	80	74	79	75	88	72	71	68	64	85	
	60	73	80	75	88	70	69	67	64	85	
	50	74	80	76	87	70	69	67	65	84	
2900	100	84	84	79	86	80	79	78	78	87	
	80	89	86	78	86	77	77	75	74	86	
	60	85	86	78	86	76	76	74	72	86	
	50	84	86	78	86	76	75	73	72	86	
4000	100	90	93	90	91	86	85	85	85	95	
	80	96	97	90	90	89	84	83	82	94	
	60	92	95	90	90	89	83	82	80	93	
	50	91	94	89	90	89	83	81	80	93	

RPM	% WOV	Outlet Sound Power, L _{Wo} [dB ref 10 ⁻¹² watts]									
		1	2	3	4	5	6	7	8	L _{WoA}	
1200	100	68	80	73	69	71	70	64	55	76	
	80	69	77	72	67	70	69	61	53	75	
	60	70	75	70	66	67	66	61	54	72	
	50	70	75	68	65	66	66	61	54	72	
1600	100	73	75	81	75	75	75	74	63	81	
	80	74	75	81	73	73	71	68	61	79	
	60	73	76	78	72	71	70	67	61	77	
	50	73	76	77	72	71	70	67	61	77	
2200	100	77	76	78	85	83	80	78	74	88	
	80	77	77	79	86	80	78	75	70	86	
	60	78	76	77	83	78	76	74	69	84	
	50	78	76	79	82	78	76	74	69	84	
2900	100	87	82	83	91	89	88	86	85	95	
	80	87	84	83	92	86	84	81	79	92	
	60	86	83	82	88	84	83	80	77	90	
	50	87	83	82	88	84	82	80	76	90	
4000	100	93	93	91	95	98	95	94	93	102	
	80	93	95	92	96	97	92	90	87	100	
	60	92	94	91	93	94	91	89	85	98	
	50	93	94	91	93	94	90	88	85	98	

Performance certified is for installation type A: Free inlet, Free outlet. Power ratings (Bhp) do not include transmission losses. Performance ratings do not include the effects of appurtenances (accessories).

The sound power level ratings shown are in decibels, referred to 10⁻¹² watts calculated per AMCA International Standard 301. Values shown are for inlet L_{Wi}, L_{WiA} and outlet L_{Wo}, L_{WoA} sound power levels for installation type A: Free inlet, Free outlet. The A-weighted sound ratings shown have been calculated per AMCA International Standard 301. Outlet ratings do not include the effects of duct end correction.

The AMCA International Certified Ratings Seal for Sound for model QEM only applies to the single L_{WiA} and L_{WoA} values.

Plenum Size 16

QEP Class I	Maximum rpm 2374
QEP Class II	Maximum rpm 3095
QEP Class III	Maximum rpm 3900
QEM	Maximum rpm 2786

Note: Model QEM does not utilize class designations.

QEP Motor on Frame Limit	215T
Minimum Motor Size	1/3 [hp]
Wheel Diameter	16.50 [in.] 419 [mm]
Peak Power	(rpm / 1571) ³ [hp] (rpm / 1732) ³ [kW]
Wheel Outlet Velocity	cfm / 2.07 [ft/min] m ³ /s / 1.22 [m/s]
Tip Speed	rpm x 4.32 [ft/min] rpm x 0.0219 [m/s]
% Wide Open Volume (%WOV)	cfm / (rpm x 0.0247) [%] m ³ /hr / (rpm x 0.0420) [%]

Imperial data – Metric data

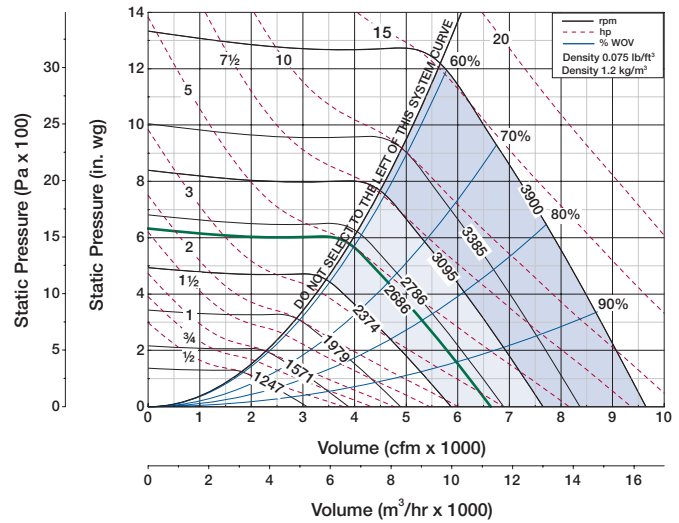

CFM	OV	STATIC PRESSURE (in. wg)																	
		1		2		3		4		5		6		7		8		9	
		RPM	BHP	RPM	BHP	RPM	BHP	RPM	BHP	RPM	BHP	RPM	BHP	RPM	BHP	RPM	BHP	RPM	BHP
3600	1730	1726	1.07	1949	1.75	2146	2.46	2328	3.20										
4000	1923	1865	1.30	2076	2.04	2264	2.81	2435	3.61	2596	4.45	2744	5.32						
4400	2115	2007	1.56	2207	2.36	2384	3.21	2549	4.06	2703	4.95	2849	5.87	2985	6.83				
4800	2307	2153	1.86	2341	2.73	2511	3.63	2669	4.56	2816	5.50	2956	6.48	3090	7.48	3216	8.52		
5200	2500	2301	2.20	2478	3.14	2641	4.10	2790	5.10	2934	6.10	3067	7.13	3197	8.19	3322	9.27	3440	10.4
5600	2692	2451	2.59	2618	3.60	2773	4.62	2918	5.68	3054	6.76	3185	7.84	3308	8.95	3429	10.1	3546	11.3
6000	2884	2602	3.02	2759	4.11	2908	5.19	3048	6.31	3178	7.46	3305	8.61	3426	9.77	3541	11.0	3654	12.2
6400	3076	2754	3.51	2903	4.68	3046	5.82	3180	7.00	3307	8.20	3427	9.44	3545	10.7	3658	11.9	3766	13.2
6800	3269	2907	4.06	3050	5.28	3186	6.51	3314	7.75	3437	9.01	3554	10.3	3666	11.6	3778	12.9	3883	14.2
7200	3461	3061	4.67	3198	5.95	3327	7.26	3451	8.55	3570	9.88	3684	11.2	3793	12.6	3898	14.0		
7600	3653	3215	5.34	3346	6.69	3469	8.08	3590	9.43	3704	10.8	3815	12.2						
8000	3846	3371	6.08	3496	7.49	3615	8.95	3731	10.4	3842	11.8								

RPM	%WOV	Inlet Sound Power, L _{wi} [dB ref 10 ⁻¹² watts]									
		1	2	3	4	5	6	7	8	L _{wiA}	
1100	100	84	78	73	69	64	62	57	48	72	
	80	87	86	77	67	62	61	53	46	74	
	60	84	86	72	65	59	58	52	47	72	
	50	85	86	72	64	58	57	52	48	72	
1500	100	75	80	77	74	69	68	66	57	77	
	80	77	77	76	71	66	65	62	55	74	
	60	75	75	75	71	64	64	60	56	73	
	50	76	75	75	70	64	64	60	57	73	
2000	100	76	79	77	86	75	75	73	68	85	
	80	76	79	78	87	73	72	68	65	84	
	60	75	80	78	86	70	70	67	65	84	
	50	75	81	78	85	70	69	67	65	83	
2800	100	86	86	82	89	82	81	80	80	90	
	80	92	88	81	88	79	79	77	76	88	
	60	88	88	81	89	78	78	76	74	88	
	50	87	88	81	89	78	77	75	74	88	
3900	100	93	96	92	93	93	88	88	88	97	
	80	99	99	92	92	92	86	86	84	96	
	60	94	98	93	92	91	85	84	82	95	
	50	94	97	92	92	91	85	84	82	95	

RPM	%WOV	Outlet Sound Power, L _{wo} [dB ref 10 ⁻¹² watts]									
		1	2	3	4	5	6	7	8	L _{woA}	
1100	100	71	80	73	70	72	71	64	54	76	
	80	71	77	73	69	71	69	61	53	75	
	60	72	76	70	67	68	66	61	54	73	
	50	72	75	69	67	67	66	61	54	72	
1500	100	75	78	83	77	77	76	74	64	83	
	80	75	77	83	75	74	73	69	61	80	
	60	75	78	80	73	72	72	68	62	78	
	50	75	78	79	73	72	71	68	62	78	
2000	100	78	77	80	86	83	80	78	75	88	
	80	78	78	81	86	80	78	75	71	87	
	60	78	77	79	83	78	77	74	69	84	
	50	79	77	80	82	78	76	74	70	84	
2800	100	89	85	86	94	91	90	88	87	97	
	80	90	87	86	94	88	86	83	81	95	
	60	88	86	85	91	86	85	82	79	92	
	50	89	86	84	91	86	84	82	78	92	
3900	100	96	96	94	98	100	98	96	95	105	
	80	96	98	95	98	99	95	92	90	103	
	60	95	96	94	96	96	93	91	88	100	
	50	96	97	93	96	96	92	90	87	100	

Performance certified is for installation type A: Free inlet, Free outlet. Power ratings (Bhp) do not include transmission losses. Performance ratings do not include the effects of appurtenances (accessories).

The sound power level ratings shown are in decibels, referred to 10⁻¹² watts calculated per AMCA International Standard 301. Values shown are for inlet L_{wi}, L_{wiA} and outlet L_{wo}, L_{woA} sound power levels for installation type A: Free inlet, Free outlet. The A-weighted sound ratings shown have been calculated per AMCA International Standard 301. Outlet ratings do not include the effects of duct end correction.

The AMCA International Certified Ratings Seal for Sound for model QEM only applies to the single L_{wiA} and L_{woA} values.

Plenum Size 18

QEP Class I	Maximum rpm 2273
QEP Class II	Maximum rpm 2964
QEP Class III	Maximum rpm 3735
QEM	Maximum rpm 2668

Note: Model QEM does not utilize class designations.

QEP Motor on Frame Limit	215T
Minimum Motor Size	1/3 [hp]
Wheel Diameter	18.25 [in.] 464 [mm]
Peak Power	(rpm / 1291) ³ [hp] (rpm / 1424) ³ [kW]
Wheel Outlet Velocity	cfm / 2.54 [ft/min] m ³ /s / 1.50 [m/s]
Tip Speed	rpm x 4.78 [ft/min] rpm x 0.0243 [m/s]
% Wide Open Volume (%WOV)	cfm / (rpm x 0.0330) [%] m ³ /hr / (rpm x 0.0561) [%]

Imperial data — Metric data

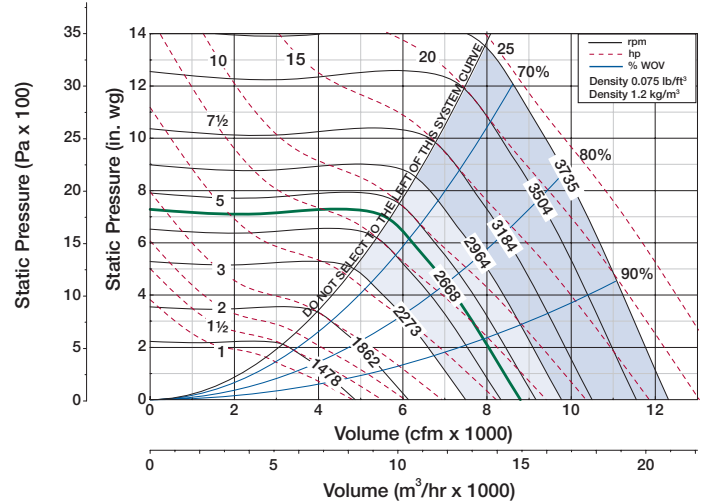

CFM	OV	STATIC PRESSURE (in. wg)																		
		1		2		3		4		5		6		7		8		9		
		RPM	BHP	RPM	BHP	RPM	BHP	RPM	BHP	RPM	BHP	RPM	BHP	RPM	BHP	RPM	BHP	RPM	BHP	
4500	1771	1563	1.51	1739	2.32	1906	3.18	2063	4.07											
5000	1968	1699	1.88	1860	2.74	2014	3.68	2162	4.65	2301	5.65									
5500	2165	1836	2.32	1984	3.23	2127	4.24	2266	5.30	2399	6.37	2525	7.46							
6000	2362	1976	2.84	2113	3.80	2248	4.86	2376	5.99	2501	7.16	2623	8.32	2739	9.52					
6500	2559	2117	3.43	2247	4.46	2371	5.57	2492	6.77	2611	8.00	2725	9.27	2837	10.5	2945	11.8			
7000	2755	2260	4.12	2383	5.21	2497	6.35	2613	7.62	2722	8.93	2833	10.3	2939	11.6	3044	13.0	3144	14.4	
7500	2952	2403	4.90	2520	6.05	2629	7.26	2737	8.56	2842	9.94	2944	11.4	3047	12.8	3145	14.3	3243	15.7	
8000	3149	2548	5.78	2658	7.00	2763	8.27	2862	9.60	2965	11.0	3062	12.5	3158	14.0	3253	15.6	3345	17.2	
8500	3346	2693	6.78	2798	8.06	2898	9.40	2993	10.8	3088	12.3	3183	13.8	3273	15.4	3364	17.0	3454	18.6	
9000	3543	2839	7.88	2939	9.23	3035	10.6	3126	12.1	3214	13.6	3306	15.2	3394	16.8	3478	18.5	3565	20.2	
9500	3740	2985	9.11	3081	10.5	3173	12.0	3261	13.5	3345	15.1	3430	16.7	3516	18.4	3599	20.2	3678	21.9	
10000	3937	3132	10.5	3224	12.0	3312	13.5	3397	15.1	3478	16.7	3556	18.3	3640	20.1	3721	21.9			

RPM	% WOV	Inlet Sound Power, L _{Wi} [dB ref 10 ⁻¹² watts]								
		1	2	3	4	5	6	7	8	L _{WiA}
1000	100	76	71	77	71	77	67	57	48	79
	80	73	69	77	68	70	60	50	44	73
	60	73	67	73	65	61	56	50	46	68
	50	73	69	70	64	59	56	51	47	67
1400	100	76	75	85	79	80	78	69	58	84
	80	74	75	82	74	72	61	54	79	
	60	73	73	80	71	66	66	59	56	75
	50	73	73	79	70	65	65	60	57	74
1900	100	79	80	87	98	84	85	78	73	96
	80	78	78	84	91	79	71	64	90	
	60	78	77	82	87	74	74	69	65	85
	50	76	76	82	86	73	73	69	66	84
2600	100	87	86	89	97	91	92	86	82	98
	80	85	84	87	94	86	86	81	74	94
	60	82	83	85	90	82	81	78	74	90
	50	82	82	83	92	81	81	78	76	91
3735	100	94	96	96	101	102	99	97	93	106
	80	92	95	95	99	99	94	92	86	102
	60	89	93	93	96	94	90	88	85	98
	50	88	92	92	96	95	89	88	85	99

RPM	% WOV	Outlet Sound Power, L _{Wo} [dB ref 10 ⁻¹² watts]									
		1	2	3	4	5	6	7	8	L _{WoA}	
1000	100	71	71	79	75	80	73	65	55	82	
	80	69	72	77	70	72	65	59	55	75	
	60	72	76	74	69	66	65	59	55	72	
	50	73	80	76	69	66	64	59	55	73	
1400	100	75	76	85	83	84	82	76	64	88	
	80	74	76	83	79	77	76	65	60	82	
	60	76	74	81	79	73	73	65	61	80	
	50	74	76	82	78	72	71	64	61	80	
1900	100	80	83	88	93	90	89	83	81	95	
	80	81	82	85	89	84	84	75	69	90	
	60	81	81	84	87	81	80	75	70	88	
	50	82	81	85	88	81	80	74	71	88	
2600	100	85	90	91	101	98	97	91	88	103	
	80	87	89	90	95	92	91	84	78	97	
	60	87	90	89	93	89	88	84	79	95	
	50	86	89	88	92	88	87	83	79	94	
3735	100	92	98	100	105	108	105	102	98	112	
	80	93	98	99	101	102	99	95	90	106	
	60	93	98	98	100	100	97	94	90	104	
	50	92	97	98	99	98	96	93	89	103	

Performance certified is for installation type A: Free inlet, Free outlet. Power ratings (Bhp) do not include transmission losses. Performance ratings do not include the effects of appurtenances (accessories).

The sound power level ratings shown are in decibels, referred to 10⁻¹² watts calculated per AMCA International Standard 301. Values shown are for inlet L_{Wi}, L_{WiA} and outlet L_{Wo}, L_{WoA} sound power levels for installation type A: Free inlet, Free outlet. The A-weighted sound ratings shown have been calculated per AMCA International Standard 301. Outlet ratings do not include the effects of duct end correction.

The AMCA International Certified Ratings Seal for Sound for model QEM only applies to the single L_{WiA} and L_{WoA} values.

Plenum Size 20

QEP Class I	Maximum rpm 2075
QEP Class II	Maximum rpm 2706
QEP Class III	Maximum rpm 3409
QEM	Maximum rpm 2327

Note: Model QEM does not utilize class designations.

QEP Motor on Frame Limit	254T
Minimum Motor Size	1/3 [hp]
Wheel Diameter	20.00 [in.] 508 [mm]
Peak Power	(rpm / 1086) ³ [hp] (rpm / 1198) ³ [kW]
Wheel Outlet Velocity	cfm / 3.05 [ft/min] m ³ /s / 1.80 [m/s]
Tip Speed	rpm x 5.24 [ft/min] rpm x 0.0266 [m/s]
% Wide Open Volume (%WOV)	cfm / (rpm x 0.0488) [%] m ³ /hr / (rpm x 0.0830) [%]

Imperial data — Metric data

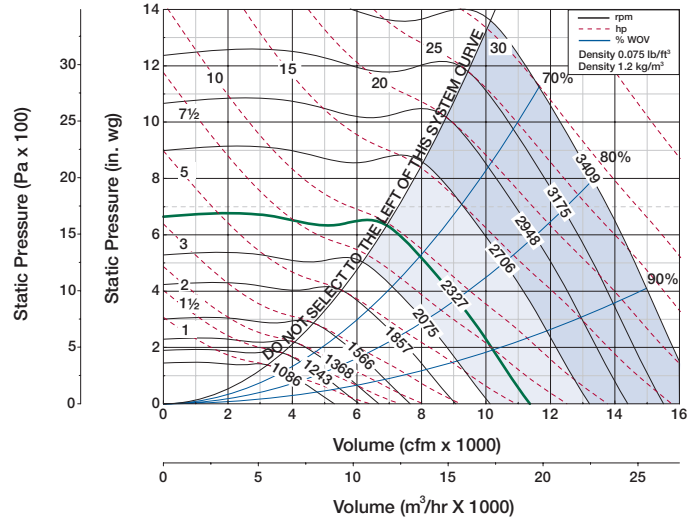

CFM	OV	STATIC PRESSURE (in. wg)																	
		1		2		3		4		5		6		7		8		9	
		RPM	BHP	RPM	BHP	RPM	BHP	RPM	BHP	RPM	BHP	RPM	BHP	RPM	BHP	RPM	BHP	RPM	BHP
6000	1967	1428	1.86	1602	2.96	1759	4.11	1908	5.37										
6500	2131	1517	2.16	1682	3.34	1832	4.57	1970	5.85	2108	7.27								
7000	2295	1609	2.51	1763	3.77	1907	5.06	2041	6.41	2168	7.84	2295	9.40						
7500	2459	1703	2.90	1847	4.23	1986	5.60	2114	7.02	2236	8.50	2355	10.1	2472	11.8				
8000	2622	1797	3.34	1934	4.73	2066	6.19	2190	7.69	2308	9.22	2418	10.8	2531	12.5	2640	14.3		
8500	2786	1892	3.83	2022	5.27	2147	6.83	2268	8.39	2381	10.0	2490	11.7	2592	13.4	2700	15.2	2802	17.1
9000	2950	1988	4.37	2111	5.87	2230	7.51	2347	9.15	2457	10.8	2562	12.6	2663	14.3	2759	16.1	2862	18.1
9500	3114	2085	4.96	2202	6.52	2317	8.23	2428	9.97	2535	11.7	2637	13.5	2736	15.4	2830	17.2	2922	19.2
10000	3278	2182	5.62	2295	7.24	2404	9.00	2509	10.9	2614	12.7	2713	14.5	2809	16.4	2902	18.4	2991	20.4
10500	3442	2279	6.33	2388	8.03	2493	9.84	2594	11.8	2695	13.7	2792	15.6	2884	17.6	2975	19.6	3063	21.7
11000	3606	2377	7.11	2482	8.88	2582	10.7	2681	12.7	2776	14.8	2871	16.8	2962	18.8	3049	20.9	3135	23.0
11500	3770	2475	7.93	2577	9.79	2672	11.7	2768	13.8	2859	15.9	2952	18.0	3041	20.1	3126	22.3	3210	24.4

RPM	% WOV	Inlet Sound Power, L _{Wi} [dB ref 10 ⁻¹² watts]									
		1	2	3	4	5	6	7	8	L _{WiA}	
900	100	77	73	77	68	68	65	54	48	73	
	80	77	72	74	66	64	60	51	47	70	
	60	77	71	73	65	61	58	51	48	69	
	50	77	72	73	65	61	58	51	47	69	
1200	100	72	78	83	73	73	71	68	57	79	
	80	73	73	79	73	69	67	60	56	76	
	60	72	73	82	71	66	65	58	56	76	
	50	72	73	82	71	66	65	58	56	76	
1700	100	81	79	89	83	80	80	77	69	87	
	80	82	78	87	80	76	75	70	65	84	
	60	81	77	86	78	73	73	67	65	82	
	50	80	77	86	78	73	73	67	65	82	
2300	100	86	86	88	91	87	87	85	81	94	
	80	80	83	85	89	83	83	79	74	90	
	60	81	81	87	90	82	80	76	73	89	
	50	81	81	88	91	82	80	76	73	90	
3409	100	93	97	97	99	98	96	95	92	103	
	80	87	92	94	96	95	92	90	85	100	
	60	88	92	93	97	95	89	87	83	99	
	50	88	92	94	98	95	89	87	83	99	

RPM	% WOV	Outlet Sound Power, L _{Wo} [dB ref 10 ⁻¹² watts]									
		1	2	3	4	5	6	7	8	L _{WoA}	
900	100	73	75	80	74	74	72	62	54	78	
	80	71	73	77	72	71	67	59	53	75	
	60	70	74	75	70	69	66	59	53	74	
	50	70	74	75	70	69	66	59	53	74	
1200	100	76	81	86	80	79	78	75	63	85	
	80	76	76	84	77	76	74	67	61	82	
	60	76	75	81	76	75	73	66	61	80	
	50	76	76	82	76	75	73	66	61	80	
1700	100	82	84	94	89	88	86	83	78	94	
	80	82	82	90	86	84	82	77	71	90	
	60	82	83	89	84	82	80	75	70	88	
	50	82	83	89	84	82	80	75	70	88	
2300	100	91	91	92	98	96	94	91	87	101	
	80	90	89	89	94	93	90	85	80	97	
	60	90	90	91	93	90	87	82	79	95	
	50	90	90	91	94	90	87	82	79	95	
3409	100	98	102	102	104	106	104	101	98	110	
	80	97	100	99	101	102	100	96	91	106	
	60	96	101	100	101	101	98	93	89	105	
	50	97	101	100	101	101	97	93	89	105	

Performance certified is for installation type A: Free inlet, Free outlet. Power ratings (Bhp) do not include transmission losses. Performance ratings do not include the effects of appurtenances (accessories).

The sound power level ratings shown are in decibels, referred to 10⁻¹² watts calculated per AMCA International Standard 301. Values shown are for inlet L_{Wi}, L_{WiA} and outlet L_{Wo}, L_{WoA} sound power levels for installation type A: Free inlet, Free outlet. The A-weighted sound ratings shown have been calculated per AMCA International Standard 301. Outlet ratings do not include the effects of duct end correction.

The AMCA International Certified Ratings Seal for Sound for model QEM only applies to the single L_{WiA} and L_{WoA} values.

Plenum Size 22

QEP Class I	Maximum rpm 1865
QEP Class II	Maximum rpm 2433
QEP Class III	Maximum rpm 3065
QEM	Maximum rpm 2190

Note: Model QEM does not utilize class designations.

QEP Motor on Frame Limit	254T
Minimum Motor Size	1/2 [hp]
Wheel Diameter	22.25 [in.] 565 [mm]
Peak Power	(rpm / 909) ³ [hp] (rpm / 1002) ³ [kW]
Wheel Outlet Velocity	cfm / 3.77 [ft/min] m ³ /s / 2.22 [m/s]
Tip Speed	rpm x 5.83 [ft/min] rpm x 0.0296 [m/s]
% Wide Open Volume (%WOV)	cfm / (rpm x 0.0672) [%] m ³ /hr / (rpm x 0.114) [%]

Imperial data — Metric data

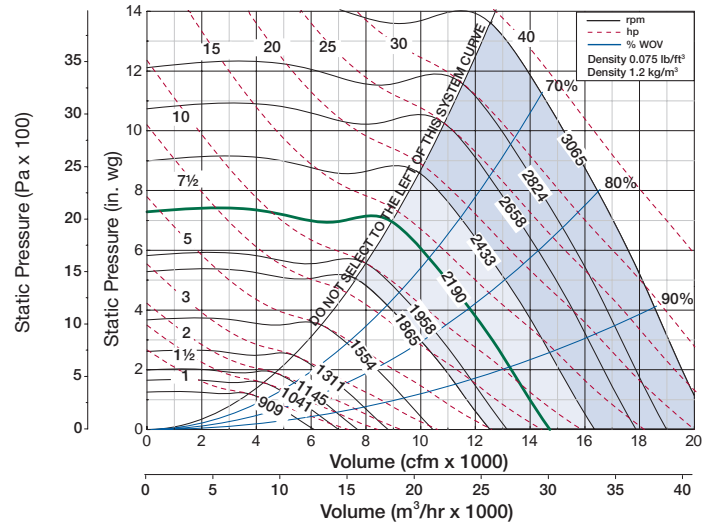

CFM	OV	STATIC PRESSURE (in. wg)																	
		1		2		3		4		5		6		7		8		9	
		RPM	BHP	RPM	BHP	RPM	BHP	RPM	BHP	RPM	BHP	RPM	BHP	RPM	BHP	RPM	BHP	RPM	BHP
7000	1856	1229	2.07	1392	3.36	1537	4.73	1678	6.27										
7800	2068	1332	2.52	1483	3.94	1620	5.42	1747	6.99	1874	8.73								
8600	2281	1438	3.06	1577	4.61	1707	6.20	1828	7.86	1943	9.63	2058	11.6						
9400	2493	1547	3.69	1675	5.35	1799	7.07	1913	8.84	2022	10.7	2127	12.6	2232	14.7				
10200	2705	1657	4.42	1777	6.17	1892	8.03	2002	9.92	2106	11.9	2205	13.9	2301	16.0	2399	18.3		
11000	2917	1768	5.25	1880	7.09	1988	9.11	2094	11.1	2193	13.2	2288	15.3	2379	17.5	2468	19.7	2560	22.1
11800	3129	1880	6.19	1985	8.13	2088	10.3	2187	12.4	2284	14.6	2375	16.8	2463	19.1	2548	21.4	2630	23.8
12600	3342	1993	7.26	2093	9.30	2190	11.5	2282	13.8	2376	16.1	2464	18.5	2550	20.9	2632	23.3	2711	25.8
13400	3554	2106	8.46	2202	10.6	2293	12.9	2383	15.3	2470	17.8	2556	20.2	2638	22.7	2717	25.3	2795	27.9
14200	3766	2220	9.76	2312	12.1	2397	14.4	2484	17.0	2566	19.6	2649	22.2	2729	24.8	2806	27.4	2881	30.1
15000	3978	2334	11.2	2423	13.6	2505	16.1	2586	18.7	2666	21.5	2744	24.2	2822	26.9	2897	29.7	2969	32.6
15800	4190	2448	12.7	2534	15.4	2613	18.0	2690	20.7	2767	23.5	2841	26.4	2916	29.3	2990	32.2	3060	35.1

RPM	% WOV	Inlet Sound Power, L _{Wi} [dB ref 10 ⁻¹² watts]									
		1	2	3	4	5	6	7	8	L _{WiA}	
800	100	77	75	76	69	68	64	54	48	73	
	80	77	73	73	67	64	59	51	47	70	
	60	77	73	72	65	61	57	51	48	69	
	50	77	74	72	65	61	57	51	48	68	
1100	100	75	81	83	74	74	72	68	57	80	
	80	75	76	80	74	70	67	61	57	77	
	60	74	76	82	72	68	65	59	57	77	
	50	74	76	82	72	67	65	59	57	76	
1500	100	81	81	90	83	80	80	76	68	87	
	80	82	80	89	80	76	74	69	65	84	
	60	81	80	87	78	73	72	67	65	82	
	50	81	80	87	78	73	72	67	65	82	
2100	100	88	88	90	92	89	88	86	82	95	
	80	82	85	87	90	85	84	79	75	91	
	60	83	83	89	90	83	81	76	74	90	
	50	83	84	89	91	83	81	76	74	91	
3065	100	95	98	98	100	99	97	95	92	104	
	80	89	94	95	98	96	92	90	86	100	
	60	90	93	95	99	95	90	87	83	100	
	50	90	94	96	99	95	90	87	83	100	

RPM	% WOV	Outlet Sound Power, L _{Wo} [dB ref 10 ⁻¹² watts]									
		1	2	3	4	5	6	7	8	L _{WoA}	
800	100	74	77	79	74	74	71	61	53	78	
	80	72	74	77	72	71	67	59	53	76	
	60	72	76	75	71	69	65	59	53	74	
	50	72	76	75	71	69	65	59	53	74	
1100	100	79	83	87	81	80	79	74	63	86	
	80	78	79	85	78	78	75	68	62	83	
	60	78	78	82	77	76	73	66	62	81	
	50	78	78	82	77	76	73	66	62	81	
1500	100	83	87	95	90	88	86	83	77	94	
	80	83	85	92	86	84	82	76	71	90	
	60	83	85	91	85	82	79	74	70	88	
	50	83	85	91	85	82	79	74	70	88	
2100	100	92	93	95	99	97	95	92	88	102	
	80	92	90	91	96	94	91	86	81	98	
	60	91	92	92	94	91	88	83	80	96	
	50	92	92	93	94	91	88	83	80	96	
3065	100	99	103	103	106	106	104	102	98	111	
	80	99	101	100	102	103	101	97	92	107	
	60	98	102	101	102	101	98	94	89	105	
	50	99	102	101	103	101	98	94	89	105	

Performance certified is for installation type A: Free inlet, Free outlet. Power ratings (Bhp) do not include transmission losses. Performance ratings do not include the effects of appurtenances (accessories).

The sound power level ratings shown are in decibels, referred to 10⁻¹² watts calculated per AMCA International Standard 301. Values shown are for inlet L_{Wi}, L_{WiA} and outlet L_{Wo}, L_{WoA} sound power levels for installation type A: Free inlet, Free outlet. The A-weighted sound ratings shown have been calculated per AMCA International Standard 301. Outlet ratings do not include the effects of duct end correction.

The AMCA International Certified Ratings Seal for Sound for model QEM only applies to the single L_{WiA} and L_{WoA} values.

Plenum Size 24

QEP Class I	Maximum rpm 1670
QEP Class II	Maximum rpm 2178
QEP Class III	Maximum rpm 2744
QEM	Maximum rpm 1960

Note: Model QEM does not utilize class designations.

QEP Motor on Frame Limit	256T
Minimum Motor Size	3/4 [hp]
Wheel Diameter	24.50 [in.] 622 [mm]
Peak Power	(rpm / 798) ³ [hp] (rpm / 880) ³ [kW]
Wheel Outlet Velocity	cfm / 4.58 [ft/min] m ³ /s / 2.69 [m/s]
Tip Speed	rpm x 6.41 [ft/min] rpm x 0.0326 [m/s]
% Wide Open Volume (%WOV)	cfm / (rpm x 0.0896) [%] m ³ /hr / (rpm x 0.152) [%]

Imperial data — Metric data

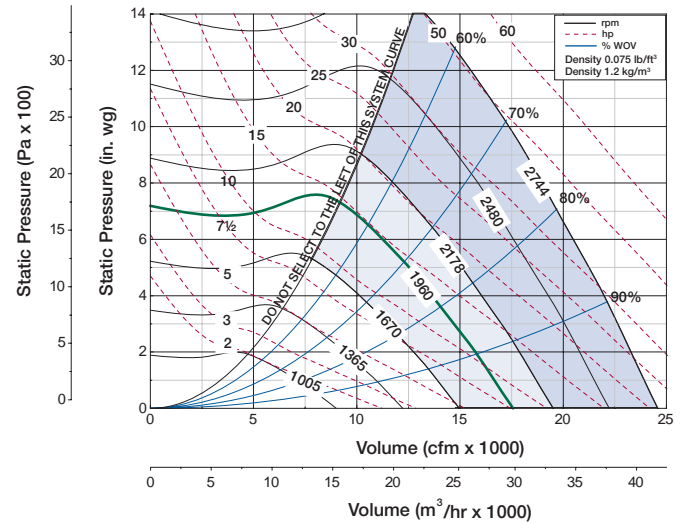

CFM	OV	STATIC PRESSURE (in. wg)																	
		1		2		3		4		5		6		7		8		9	
		RPM	BHP	RPM	BHP	RPM	BHP	RPM	BHP	RPM	BHP	RPM	BHP	RPM	BHP	RPM	BHP	RPM	BHP
8000	1750	1087	2.08	1245	3.59	1389	5.22	1520	6.88	1644	8.62								
9000	1969	1180	2.54	1329	4.18	1463	5.98	1587	7.81	1703	9.68	1815	11.6						
10000	2188	1275	3.07	1418	4.86	1541	6.77	1659	8.82	1770	10.8	1873	12.9	1976	15.1	2073	17.3		
11000	2407	1373	3.69	1509	5.64	1625	7.66	1737	9.82	1841	12.1	1942	14.3	2036	16.6	2131	18.9	2221	21.3
12000	2625	1474	4.41	1601	6.49	1714	8.66	1817	10.9	1918	13.3	2013	15.8	2106	18.2	2193	20.7	2280	23.2
13000	2844	1577	5.23	1695	7.44	1805	9.78	1903	12.2	1997	14.7	2090	17.3	2178	20.0	2264	22.6	2345	25.3
14000	3063	1681	6.17	1790	8.51	1896	11.0	1992	13.5	2081	16.2	2169	18.9	2255	21.8	2336	24.7	2416	27.5
15000	3282	1785	7.23	1886	9.71	1989	12.3	2083	15.0	2169	17.8	2250	20.6	2333	23.6	2413	26.6	2489	29.8
16000	3501	1890	8.42	1986	11.0	2083	13.8	2174	16.7	2259	19.6	2338	22.5	2414	25.6	2491	28.7	2566	32.0
17000	3719	1996	9.74	2088	12.5	2178	15.4	2267	18.4	2349	21.5	2427	24.6	2500	27.7	2572	31.0	2645	34.4
18000	3938	2103	11.2	2191	14.1	2274	17.1	2360	20.3	2441	23.5	2517	26.8	2589	30.1	2658	33.4	2726	36.9
19000	4157	2210	12.8	2294	15.9	2372	19.1	2455	22.3	2534	25.7	2608	29.2	2679	32.6				

RPM	% WOV	Inlet Sound Power, L _{Wi} [dB ref 10 ⁻¹² watts]									
		1	2	3	4	5	6	7	8	L _{WiA}	
750	100	71	87	79	69	67	68	57	52	76	
	80	71	83	76	66	64	59	51	45	72	
	60	81	82	78	67	61	56	49	43	72	
	50	81	82	78	67	61	56	49	43	72	
1000	100	75	80	91	78	74	72	67	60	84	
	80	72	86	90	75	70	68	60	55	83	
	60	73	83	84	71	66	64	58	55	78	
	50	72	82	85	71	66	64	58	55	78	
1400	100	79	83	98	85	83	81	76	70	92	
	80	76	81	97	82	78	76	70	66	90	
	60	75	79	92	77	73	72	68	65	85	
	50	74	78	90	75	71	70	67	66	82	
2000	100	88	88	95	100	94	91	86	82	100	
	80	84	86	91	96	89	86	80	76	96	
	60	83	89	92	94	83	81	77	75	93	
	50	82	90	93	92	81	79	76	75	91	
2744	100	93	97	100	105	103	99	95	91	107	
	80	89	93	96	102	99	94	90	85	103	
	60	89	95	98	100	95	89	85	82	100	
	50	88	95	99	99	93	87	84	82	99	

RPM	% WOV	Outlet Sound Power, L _{Wo} [dB ref 10 ⁻¹² watts]									
		1	2	3	4	5	6	7	8	L _{WoA}	
750	100	76	85	78	74	74	74	64	62	84	
	80	79	82	76	73	72	64	57	52	80	
	60	78	81	74	71	71	64	58	52	75	
	50	77	82	72	69	70	64	58	53	74	
1000	100	75	83	90	85	81	78	73	63	87	
	80	73	84	87	82	77	73	65	60	84	
	60	77	85	84	80	75	70	64	62	82	
	50	78	85	83	80	74	69	64	64	81	
1400	100	82	84	101	94	91	86	82	74	97	
	80	79	83	98	90	87	82	76	70	93	
	60	81	83	93	85	83	78	73	70	89	
	50	82	83	91	83	81	77	71	70	87	
2000	100	89	91	98	105	102	96	91	88	106	
	80	88	90	95	102	97	92	85	81	102	
	60	91	94	94	96	92	86	81	79	97	
	50	94	95	96	93	90	84	80	78	95	
2744	100	94	99	102	110	110	106	101	96	113	
	80	93	98	101	108	107	101	96	90	110	
	60	97	101	102	102	101	96	91	87	105	
	50	100	104	104	100	98	94	89	86	103	

Performance certified is for installation type A: Free inlet, Free outlet. Power ratings (Bhp) do not include transmission losses. Performance ratings do not include the effects of appurtenances (accessories).

The sound power level ratings shown are in decibels, referred to 10⁻¹² watts calculated per AMCA International Standard 301. Values shown are for inlet L_{Wi}, L_{WiA} and outlet L_{Wo}, L_{WoA} sound power levels for installation type A: Free inlet, Free outlet. The A-weighted sound ratings shown have been calculated per AMCA International Standard 301. Outlet ratings do not include the effects of duct end correction.

The AMCA International Certified Ratings Seal for Sound for model QEM only applies to the single L_{WiA} and L_{WoA} values.

Plenum Size 27

QEP Class I	Maximum rpm 1450
QEP Class II	Maximum rpm 1890
QEP Class III	Maximum rpm 2382
QEM	Maximum rpm 1701

Note: Model QEM does not utilize class designations.

QEP Motor on Frame Limit	256T
Minimum Motor Size	3/4 [hp]
Wheel Diameter	27.00 [in.] 686 [mm]
Peak Power	(rpm / 678) ³ [hp] (rpm / 748) ³ [kW]
Wheel Outlet Velocity	cfm / 5.55 [ft/min] m ³ /s / 3.27 [m/s]
Tip Speed	rpm x 7.07 [ft/min] rpm x 0.0359 [m/s]
% Wide Open Volume (%WOV)	cfm / (rpm x 0.120) [%] m ³ /hr / (rpm x 0.204) [%]

Imperial data — Metric data

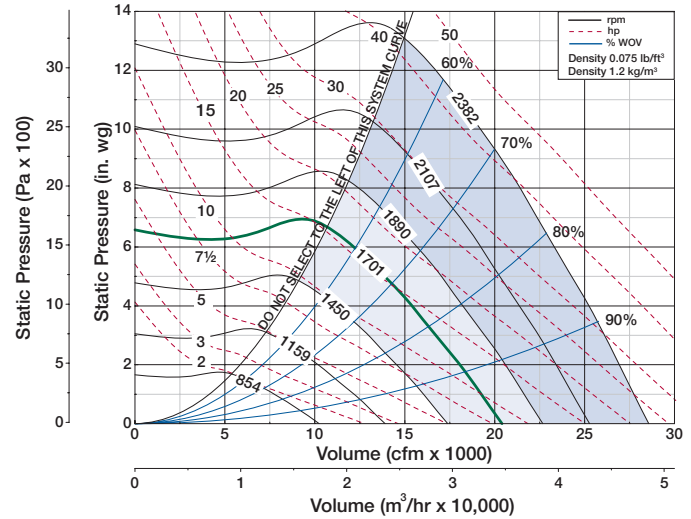

CFM	OV	STATIC PRESSURE (in. wg)																	
		1		2		3		4		5		6		7		8		9	
		RPM	BHP	RPM	BHP	RPM	BHP	RPM	BHP	RPM	BHP	RPM	BHP	RPM	BHP	RPM	BHP	RPM	BHP
10000	1801	1006	2.65	1147	4.52	1275	6.56	1391	8.61	1504	10.8								
11000	1981	1076	3.11	1210	5.12	1331	7.31	1443	9.55	1548	11.8	1650	14.2	1744	16.7				
12000	2162	1147	3.64	1277	5.80	1390	8.10	1497	10.6	1598	13.0	1693	15.5	1787	18.1	1875	20.7		
13000	2342	1219	4.24	1344	6.55	1451	8.96	1555	11.6	1651	14.2	1743	16.9	1831	19.6	1918	22.4	2000	25.2
14000	2522	1294	4.92	1413	7.38	1517	9.92	1614	12.6	1707	15.5	1796	18.3	1880	21.2	1962	24.1	2043	27.1
15000	2702	1370	5.69	1482	8.27	1584	11.0	1675	13.8	1766	16.8	1851	19.9	1933	22.9	2012	25.9	2087	29.1
16000	2882	1447	6.54	1553	9.25	1652	12.1	1741	15.1	1825	18.1	1909	21.4	1988	24.7	2065	27.9	2139	31.2
17000	3063	1525	7.49	1624	10.3	1720	13.4	1807	16.4	1888	19.6	1968	23.0	2046	26.4	2119	30.0	2192	33.4
18000	3243	1603	8.54	1696	11.5	1790	14.7	1875	17.9	1954	21.2	2029	24.7	2104	28.2	2177	31.9	2246	35.7
19000	3423	1681	9.69	1770	12.8	1859	16.1	1943	19.5	2020	23.0	2093	26.5	2165	30.2	2235	34.0	2303	37.9
20000	3603	1760	11.0	1845	14.2	1930	17.6	2012	21.2	2088	24.8	2159	28.5	2226	32.2	2294	36.2	2362	40.2
21000	3783	1840	12.3	1922	15.7	2002	19.3	2081	23.0	2156	26.8	2226	30.6	2292	34.5	2355	38.5		

RPM	% WOV	Inlet Sound Power, L _{Wi} [dB ref 10 ⁻¹² watts]									
		1	2	3	4	5	6	7	8	9	L _{WiA}
650	100	74	88	76	68	67	65	56	50	76	
	80	73	84	74	65	63	58	50	44	72	
	60	81	83	75	66	60	54	47	42	71	
	50	81	83	75	66	60	54	47	42	71	
900	100	76	83	90	78	74	72	67	60	83	
	80	75	87	89	75	70	67	60	55	82	
	60	76	84	83	71	67	64	58	55	77	
	50	74	83	83	71	66	64	58	55	77	
1300	100	81	86	100	87	84	82	77	70	93	
	80	79	85	99	83	79	77	71	66	91	
	60	77	82	94	78	75	73	69	66	86	
	50	76	81	91	76	72	71	68	67	84	
1700	100	87	89	95	98	92	89	85	80	98	
	80	83	86	92	94	87	84	79	75	94	
	60	84	89	91	91	82	79	76	74	91	
	50	83	90	92	89	80	78	75	74	89	
2382	100	94	97	101	105	102	98	94	90	107	
	80	90	94	97	102	98	93	89	84	102	
	60	90	96	98	99	93	88	85	82	99	
	50	89	96	99	98	91	86	83	81	98	

RPM	% WOV	Outlet Sound Power, L _{Wo} [dB ref 10 ⁻¹² watts]									
		1	2	3	4	5	6	7	8	9	L _{WoA}
650	100	78	86	77	74	74	71	67	60	87	
	80	80	83	75	73	70	63	56	50	75	
	60	79	82	74	71	69	62	56	51	74	
	50	78	83	71	69	69	63	57	52	73	
900	100	77	85	90	85	81	78	72	62	87	
	80	76	86	87	82	77	72	65	60	84	
	60	79	85	84	80	75	70	64	62	82	
	50	80	85	83	80	74	69	65	65	81	
1300	100	84	88	103	95	92	87	82	75	98	
	80	81	87	99	91	88	83	76	71	94	
	60	83	86	95	87	84	79	74	71	90	
	50	84	86	93	84	82	77	73	71	88	
1700	100	89	92	99	104	100	94	90	86	104	
	80	88	91	96	101	95	90	84	79	101	
	60	91	93	94	94	90	84	80	78	95	
	50	94	95	94	92	88	83	79	77	93	
2382	100	95	100	104	110	109	105	100	95	113	
	80	94	99	102	108	105	100	94	89	109	
	60	98	102	102	102	100	95	90	86	104	
	50	100	104	103	100	97	93	88	85	102	

Performance certified is for installation type A: Free inlet, Free outlet. Power ratings (Bhp) do not include transmission losses. Performance ratings do not include the effects of appurtenances (accessories).

The sound power level ratings shown are in decibels, referred to 10⁻¹² watts calculated per AMCA International Standard 301. Values shown are for inlet L_{Wi}, L_{WiA} and outlet L_{Wo}, L_{WoA} sound power levels for installation type A: Free inlet, Free outlet. The A-weighted sound ratings shown have been calculated per AMCA International Standard 301. Outlet ratings do not include the effects of duct end correction.

The AMCA International Certified Ratings Seal for Sound for model QEM only applies to the single L_{WiA} and L_{WoA} values.

Plenum Size 30

QEP Class I	Maximum rpm 1305
QEP Class II	Maximum rpm 1702
QEP Class III	Maximum rpm 2144
QEM	Maximum rpm 1532

Note: Model QEM does not utilize class designations.

QEP Motor on Frame Limit	284T
Minimum Motor Size	3/4 [hp]
Wheel Diameter	30.00 [in.] 762 [mm]
Peak Power	(rpm / 569) ³ [hp] (rpm / 627) ³ [kW]
Wheel Outlet Velocity	cfm / 6.86 [ft/min] m ³ /s / 4.04 [m/s]
Tip Speed	rpm x 7.85 [ft/min] rpm x 0.0399 [m/s]
% Wide Open Volume (%WOV)	cfm / (rpm x 0.165) [%] m ³ /hr / (rpm x 0.280) [%]

Imperial data — Metric data

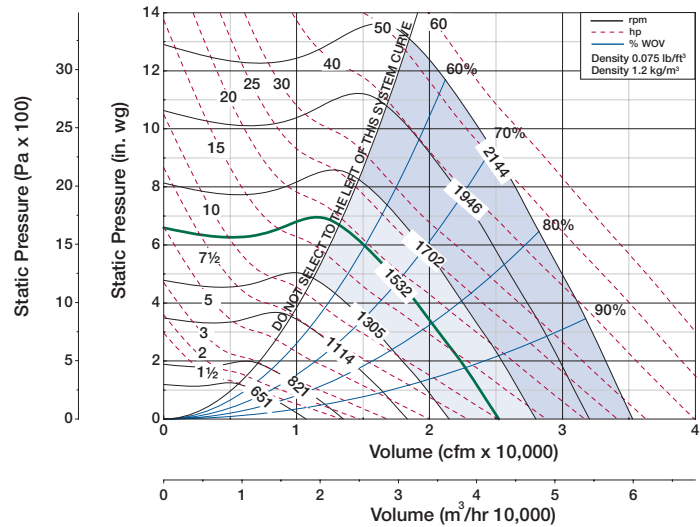

CFM	OV	STATIC PRESSURE (in. wg)																	
		1		2		3		4		5		6		7		8		9	
		RPM	BHP	RPM	BHP	RPM	BHP	RPM	BHP	RPM	BHP	RPM	BHP	RPM	BHP	RPM	BHP	RPM	BHP
15000	2189	1042	4.60	1158	7.29	1259	10.2	1355	13.2	1445	16.3	1530	19.4	1614	22.6	1693	25.9		
16000	2335	1094	5.21	1207	8.05	1304	11.0	1397	14.2	1484	17.5	1567	20.8	1646	24.1	1724	27.5	1798	31.0
17000	2481	1149	5.88	1257	8.87	1352	12.0	1440	15.3	1525	18.8	1605	22.2	1681	25.7	1756	29.3	1830	32.9
18000	2627	1204	6.61	1308	9.73	1400	13.0	1484	16.4	1567	20.0	1644	23.8	1720	27.4	1791	31.1	1862	34.8
19000	2773	1260	7.42	1359	10.7	1449	14.1	1531	17.6	1610	21.3	1686	25.2	1759	29.1	1829	33.0	1896	36.9
20000	2919	1316	8.30	1410	11.7	1499	15.3	1579	18.9	1654	22.7	1728	26.8	1799	30.9	1868	35.0	1935	39.0
21000	3065	1373	9.25	1462	12.8	1549	16.5	1627	20.3	1700	24.2	1771	28.4	1841	32.6	1908	37.0	1973	41.2
22000	3211	1430	10.3	1514	13.9	1599	17.8	1677	21.8	1748	25.8	1816	30.0	1884	34.4	1950	39.0	2012	43.5
23000	3357	1487	11.4	1568	15.2	1650	19.2	1726	23.4	1796	27.5	1862	31.9	1927	36.3	1992	41.0	2054	45.8
24000	3503	1544	12.6	1623	16.6	1701	20.7	1776	25.0	1845	29.3	1910	33.8	1972	38.4	2035	43.1	2096	48.0
25000	3649	1602	13.9	1678	18.0	1753	22.3	1826	26.7	1894	31.2	1958	35.8	2018	40.5	2079	45.3	2139	50.3
26000	3795	1660	15.3	1734	19.6	1805	23.9	1877	28.5	1944	33.2	2007	37.9	2066	42.7	2123	47.7		

RPM	% WOV	Inlet Sound Power, L _{Wi} [dB ref 10 ⁻¹² watts]									
		1	2	3	4	5	6	7	8	L _{WiA}	
600	100	77	89	77	70	69	65	57	51	77	
	80	76	86	74	67	64	58	50	45	73	
	60	83	84	76	67	61	55	48	43	72	
	50	83	84	76	67	61	55	48	43	72	
	800	100	78	86	88	78	75	72	66	59	83
80	78	89	86	74	70	66	60	55	81		
60	78	84	81	71	67	63	58	55	76		
50	77	84	81	71	67	63	58	55	76		
1100	100	81	89	97	85	83	80	75	68	91	
	80	79	88	95	82	78	75	70	65	88	
	60	77	85	90	77	74	71	68	65	83	
	50	76	83	88	74	72	70	68	66	81	
	1500	100	87	91	97	97	92	89	84	80	98
80		84	88	93	93	87	84	79	74	94	
60		85	90	92	89	82	79	76	74	90	
50		85	91	91	87	80	78	75	74	89	
2144		100	95	99	102	106	102	98	94	90	107
	80	91	95	99	102	98	93	89	84	103	
	60	92	97	100	99	93	88	85	82	100	
	50	91	97	100	98	91	86	84	82	99	

RPM	% WOV	Outlet Sound Power, L _{Wo} [dB ref 10 ⁻¹² watts]									
		1	2	3	4	5	6	7	8	L _{WoA}	
600	100	81	88	79	76	75	71	61	53	80	
	80	81	84	77	74	71	63	57	51	76	
	60	81	84	75	72	70	63	57	52	75	
	50	80	84	72	71	70	64	58	53	74	
	800	100	79	87	90	85	81	77	71	62	87
80	78	87	87	82	77	72	65	60	83		
60	81	85	84	80	75	69	65	63	81		
50	81	85	83	79	74	69	65	66	81		
1100	100	84	91	101	94	90	86	80	73	97	
	80	81	89	97	90	86	81	75	70	93	
	60	83	88	93	86	82	77	73	70	89	
	50	83	87	90	83	80	76	72	70	87	
	1500	100	89	94	101	103	99	94	90	86	104
80		88	92	99	100	95	89	83	79	100	
60		92	94	94	94	90	84	80	78	95	
50		94	96	93	92	87	82	79	78	93	
2144		100	97	101	106	111	109	105	100	96	113
	80	95	100	104	109	106	100	94	89	110	
	60	99	103	103	103	100	95	90	86	104	
	50	102	105	103	101	98	93	89	86	103	

Performance certified is for installation type A: Free inlet, Free outlet. Power ratings (Bhp) do not include transmission losses. Performance ratings do not include the effects of appurtenances (accessories).

The sound power level ratings shown are in decibels, referred to 10⁻¹² watts calculated per AMCA International Standard 301. Values shown are for inlet L_{Wi}, L_{WiA} and outlet L_{Wo}, L_{WoA} sound power levels for installation type A: Free inlet, Free outlet. The A-weighted sound ratings shown have been calculated per AMCA International Standard 301. Outlet ratings do not include the effects of duct end correction.

The AMCA International Certified Ratings Seal for Sound for model QEM only applies to the single L_{WiA} and L_{WoA} values.

Plenum Size 33

QEP Class I	Maximum rpm 1186
QEP Class II	Maximum rpm 1547
QEP Class III	Maximum rpm 1949
QEM	Maximum rpm 1392

Note: Model QEM does not utilize class designations.

QEP Motor on Frame Limit	286T
Minimum Motor Size	1½ [hp]
Wheel Diameter	33.00 [in.] 838 [mm]
Peak Power	(rpm / 485) ³ [hp] (rpm / 535) ³ [kW]
Wheel Outlet Velocity	cfm / 8.30 [ft/min] m ³ /s / 4.89 [m/s]
Tip Speed	rpm x 8.64 [ft/min] rpm x 0.0439 [m/s]
% Wide Open Volume (%WOV)	cfm / (rpm x 0.219) [%] m ³ /hr / (rpm x 0.372) [%]

Imperial data — Metric data

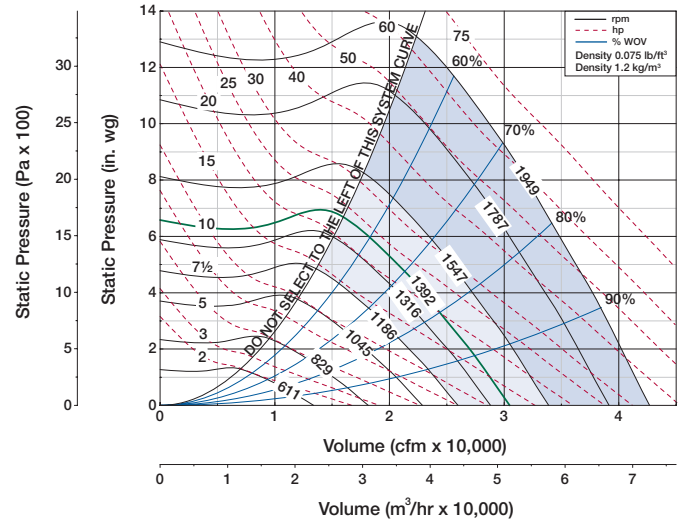

CFM	OV	STATIC PRESSURE (in. wg)																		
		1		2		3		4		5		6		7		8		9		
		RPM	BHP	RPM	BHP	RPM	BHP	RPM	BHP	RPM	BHP	RPM	BHP	RPM	BHP	RPM	BHP	RPM	BHP	
14000	1688	788	3.57	908	6.24	1016	9.10	1116	12.0	1208	15.1									
16000	1930	864	4.44	975	7.38	1075	10.6	1168	13.9	1256	17.2	1339	20.7							
18000	2171	941	5.48	1047	8.71	1139	12.2	1227	15.9	1309	19.5	1387	23.2	1464	27.1	1535	31.1			
20000	2412	1021	6.72	1122	10.3	1208	13.9	1290	17.9	1368	22.0	1443	26.0	1512	30.2	1583	34.4	1650	38.7	
22000	2653	1104	8.17	1197	12.0	1281	16.0	1357	20.1	1431	24.5	1501	29.1	1570	33.5	1634	38.0	1698	42.6	
24000	2895	1188	9.86	1274	13.9	1355	18.2	1428	22.6	1497	27.2	1565	32.1	1629	37.1	1692	41.9	1753	46.7	
26000	3136	1273	11.8	1352	16.1	1430	20.7	1501	25.4	1566	30.3	1630	35.3	1693	40.5	1753	45.9	1811	51.2	
28000	3377	1359	14.0	1432	18.6	1507	23.5	1576	28.6	1639	33.6	1699	38.9	1758	44.3	1816	49.9	1872	55.7	
30000	3618	1446	16.5	1515	21.4	1584	26.5	1651	31.9	1713	37.3	1771	42.8	1826	48.4	1881	54.3	1936	60.3	
32000	3860	1533	19.3	1599	24.5	1662	29.9	1727	35.5	1788	41.3	1844	47.1	1898	53.0					
34000	4101	1620	22.4	1683	28.0	1742	33.6	1804	39.5	1863	45.6	1919	51.7							
36000	4342	1708	25.9	1768	31.8	1825	37.7	1882	43.9	1939	50.2									

RPM	% WOV	Inlet Sound Power, L _{Wi} [dB ref 10 ⁻¹² watts]								
		1	2	3	4	5	6	7	8	L _{WiA}
550	100	80	88	77	71	70	65	57	51	76
	80	79	85	74	67	64	58	51	45	73
	60	84	84	75	67	61	55	49	43	72
	50	84	84	75	67	61	55	49	43	72
750	100	80	89	88	79	76	73	67	60	84
	80	81	91	87	75	72	67	61	56	81
	60	80	86	82	72	68	64	59	56	77
	50	79	86	82	72	68	64	60	57	77
1050	100	84	92	97	87	85	82	76	70	92
	80	81	91	96	83	80	76	71	66	89
	60	80	88	91	79	76	73	70	67	85
	50	79	86	88	76	73	72	69	68	83
1400	100	89	93	99	98	93	90	85	81	99
	80	86	90	95	94	88	84	80	75	95
	60	87	92	94	90	83	80	77	75	91
	50	87	93	93	88	81	79	76	76	90
1949	100	96	100	104	106	103	99	95	90	107
	80	93	97	101	102	98	93	89	84	103
	60	93	98	101	99	93	89	86	83	100
	50	93	99	101	98	91	87	85	83	99

RPM	% WOV	Outlet Sound Power, L _{Wo} [dB ref 10 ⁻¹² watts]								
		1	2	3	4	5	6	7	8	L _{WoA}
550	100	83	87	79	77	76	71	61	53	80
	80	83	84	77	75	71	64	57	51	77
	60	82	83	75	73	70	63	58	52	75
	50	81	83	73	72	70	64	58	53	75
750	100	81	89	91	86	82	78	72	62	88
	80	81	88	88	83	78	72	66	61	84
	60	83	86	85	81	76	70	66	64	83
	50	83	86	85	80	75	70	67	67	82
1050	100	86	95	102	96	92	87	82	74	98
	80	83	92	99	92	88	82	76	71	94
	60	85	91	94	87	84	79	74	71	90
	50	85	90	92	85	82	77	73	72	88
1400	100	91	96	103	105	100	95	91	87	105
	80	90	94	101	101	96	90	84	80	101
	60	93	95	96	95	90	85	81	79	96
	50	96	97	94	93	88	83	81	79	94
1949	100	98	102	108	112	110	105	100	96	114
	80	97	101	106	109	106	100	94	89	110
	60	101	104	103	103	100	95	90	87	105
	50	103	106	103	101	98	93	89	86	103

Performance certified is for installation type A: Free inlet, Free outlet. Power ratings (Bhp) do not include transmission losses. Performance ratings do not include the effects of appurtenances (accessories).

The sound power level ratings shown are in decibels, referred to 10⁻¹² watts calculated per AMCA International Standard 301. Values shown are for inlet L_{Wi}, L_{WiA} and outlet L_{Wo}, L_{WoA} sound power levels for installation type A: Free inlet, Free outlet. The A-weighted sound ratings shown have been calculated per AMCA International Standard 301. Outlet ratings do not include the effects of duct end correction.

The AMCA International Certified Ratings Seal for Sound for model QEM only applies to the single L_{WiA} and L_{WoA} values.

Plenum Size 36

QEP Class I	Maximum rpm 1047
QEP Class II	Maximum rpm 1365
QEP Class III	Maximum rpm 1720
QEM	Maximum rpm 1229

Note: Model QEM does not utilize class designations.

QEP Motor on Frame Limit	324T
Minimum Motor Size	1½ [hp]
Wheel Diameter	36.50 [in.] 927 [mm]
Peak Power	(rpm / 401) ³ [hp] (rpm / 442) ³ [kW]
Wheel Outlet Velocity	cfm / 10.2 [ft/min] m ³ /s / 5.98 [m/s]
Tip Speed	rpm x 9.56 [ft/min] rpm x 0.0485 [m/s]
% Wide Open Volume (%WOV)	cfm / (rpm x 0.306) [%] m ³ /hr / (rpm x 0.520) [%]

Imperial data — Metric data

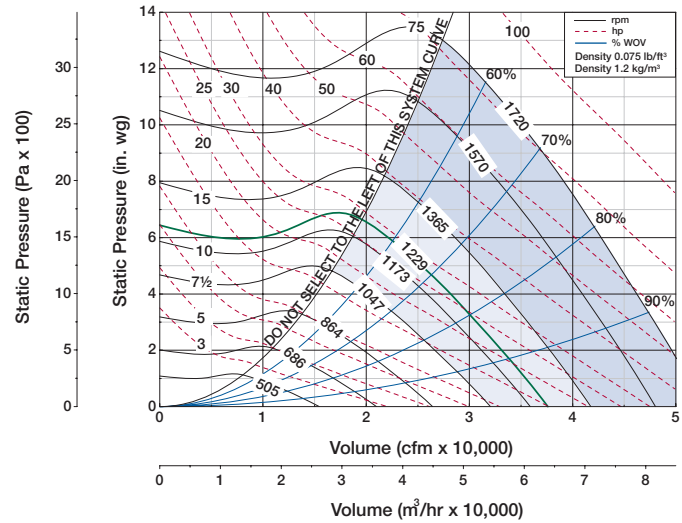

CFM	OV	STATIC PRESSURE (in. wg)																	
		1		2		3		4		5		6		7		8		9	
		RPM	BHP	RPM	BHP	RPM	BHP	RPM	BHP	RPM	BHP	RPM	BHP	RPM	BHP	RPM	BHP	RPM	BHP
18000	1773	717	4.73	822	8.10	916	11.7	1001	15.5	1083	19.5								
20000	1970	772	5.65	871	9.29	959	13.3	1042	17.3	1117	21.6	1192	25.9						
22000	2167	828	6.72	922	10.6	1006	14.8	1084	19.3	1157	23.8	1225	28.4	1294	33.3	1357	38.2		
24000	2364	886	7.93	975	12.2	1055	16.6	1129	21.3	1199	26.2	1266	31.1	1328	36.2	1391	41.4	1451	46.8
26000	2561	944	9.29	1029	13.9	1105	18.6	1176	23.5	1243	28.8	1307	34.0	1369	39.3	1427	44.8	1485	50.4
28000	2758	1004	10.8	1084	15.7	1157	20.7	1225	25.9	1290	31.4	1351	37.1	1411	42.7	1468	48.4	1522	54.3
30000	2955	1063	12.6	1140	17.8	1210	23.1	1275	28.5	1338	34.2	1397	40.2	1453	46.3	1509	52.3	1563	58.4
32000	3152	1124	14.5	1197	20.0	1264	25.7	1328	31.4	1386	37.3	1444	43.5	1500	49.9	1552	56.5	1605	62.9
34000	3349	1184	16.7	1254	22.5	1320	28.4	1380	34.5	1438	40.7	1493	47.1	1546	53.7	1598	60.5	1648	67.5
36000	3546	1246	19.1	1313	25.2	1375	31.5	1434	37.9	1490	44.3	1543	50.9	1595	57.8	1645	64.8	1694	72.0
38000	3743	1307	21.7	1372	28.1	1432	34.7	1489	41.4	1543	48.2	1595	55.1	1644	62.1	1694	69.4		
40000	3940	1369	24.6	1431	31.3	1489	38.3	1544	45.2	1597	52.4	1647	59.5	1695	66.8				

RPM	% WOV	Inlet Sound Power, L _{wi} [dB ref 10 ⁻¹² watts]									
		1	2	3	4	5	6	7	8	L _{wiA}	
500	100	79	87	76	68	72	62	58	53	76	
	80	77	84	73	63	62	56	53	49	71	
	60	78	83	71	61	59	55	52	48	70	
	50	81	79	70	62	60	55	53	49	68	
700	100	83	95	84	76	78	74	68	62	84	
	80	81	91	80	71	70	64	62	57	79	
	60	80	90	78	68	67	62	59	57	77	
	50	80	91	80	68	67	62	60	58	78	
1000	100	86	95	100	87	85	83	78	74	94	
	80	86	93	100	83	79	75	71	68	92	
	60	84	93	95	80	75	71	68	67	87	
	50	84	96	96	80	75	71	69	67	89	
1300	100	93	95	101	94	93	88	85	81	98	
	80	88	91	99	90	89	82	77	75	94	
	60	86	89	97	87	85	77	75	74	91	
	50	86	92	101	87	83	77	76	75	94	
1720	100	98	101	105	103	99	96	93	89	105	
	80	93	97	103	100	95	91	85	82	101	
	60	91	95	100	98	92	86	82	80	98	
	50	90	97	104	100	91	86	82	81	100	

RPM	% WOV	Outlet Sound Power, L _{wO} [dB ref 10 ⁻¹² watts]									
		1	2	3	4	5	6	7	8	L _{wO} A	
500	100	77	85	79	78	78	70	66	56	81	
	80	76	85	75	74	73	66	62	55	77	
	60	78	81	73	73	72	63	60	55	76	
	50	80	80	72	73	72	61	59	55	75	
700	100	79	92	85	84	83	78	75	68	87	
	80	79	92	83	81	80	72	70	64	84	
	60	81	89	84	81	79	71	67	63	83	
	50	89	91	87	85	82	74	69	64	87	
1000	100	84	92	100	95	91	87	84	79	97	
	80	84	90	98	92	87	82	80	75	94	
	60	85	92	95	90	85	80	78	72	92	
	50	88	98	96	91	87	81	78	73	93	
1300	100	92	96	104	102	99	93	90	87	104	
	80	91	93	102	99	95	88	84	81	100	
	60	93	95	100	95	92	85	82	78	97	
	50	93	98	102	95	91	85	82	77	98	
1720	100	97	102	107	109	106	102	97	94	111	
	80	96	100	104	107	102	97	92	88	107	
	60	98	102	104	104	99	94	89	86	105	
	50	98	103	107	105	98	94	89	85	105	

Performance certified is for installation type A: Free inlet, Free outlet. Power ratings (Bhp) do not include transmission losses. Performance ratings do not include the effects of appurtenances (accessories).

The sound power level ratings shown are in decibels, referred to 10⁻¹² watts calculated per AMCA International Standard 301. Values shown are for inlet L_{wi}, L_{wiA} and outlet L_{wO}, L_{wOA} sound power levels for installation type A: Free inlet, Free outlet. The A-weighted sound ratings shown have been calculated per AMCA International Standard 301. Outlet ratings do not include the effects of duct end correction.

The AMCA International Certified Ratings Seal for Sound for model QEM only applies to the single L_{wiA} and L_{wOA} values.

Plenum Size 40

QEP Class I	Maximum rpm 949
QEP Class II	Maximum rpm 1238
QEP Class III	Maximum rpm 1560

QEP Motor on Frame Limit	326T
Minimum Motor Size	2 [hp]
Wheel Diameter	40.25 [in.] 1022 [mm]
Peak Power	(rpm / 341) ³ [hp] (rpm / 376) ³ [kW]
Wheel Outlet Velocity	cfm / 12.3 [ft/min] m ³ /s / 7.27 [m/s]
Tip Speed	rpm x 10.5 [ft/min] rpm x 0.0535 [m/s]
% Wide Open Volume (%WOV)	cfm / (rpm x 0.410) [%] m ³ /hr / (rpm x 0.697) [%]

Imperial data — Metric data

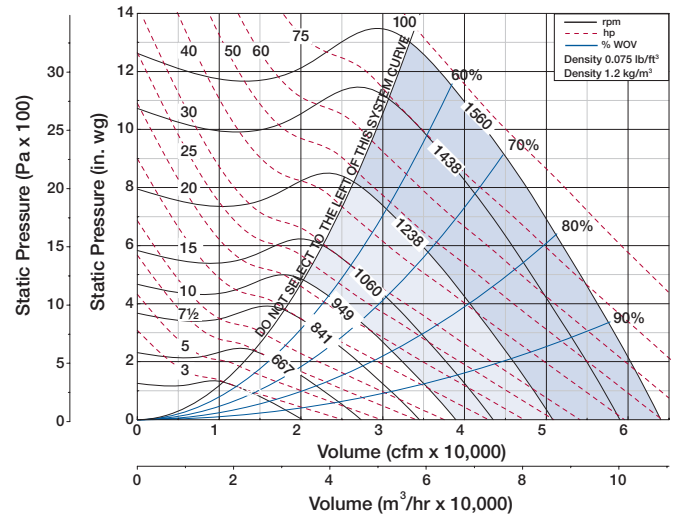

CFM	OV	STATIC PRESSURE (in. wg)																	
		1		2		3		4		5		6		7		8		9	
		RPM	BHP	RPM	BHP	RPM	BHP	RPM	BHP	RPM	BHP	RPM	BHP	RPM	BHP	RPM	BHP	RPM	BHP
26000	2106	735	7.75	822	12.4	899	17.4	971	22.7	1038	28.1	1102	33.6	1164	39.4	1222	45.3	1286	51.5
28000	2269	778	8.90	861	13.9	935	19.1	1003	24.8	1069	30.4	1130	36.2	1189	42.2	1247	48.4	1301	54.8
30000	2431	821	10.2	900	15.5	971	21.0	1038	26.8	1100	32.9	1160	39.0	1217	45.3	1272	51.7	1326	58.3
32000	2593	865	11.6	941	17.2	1009	23.0	1074	29.1	1134	35.5	1192	42.0	1247	48.5	1300	55.2	1352	62.1
34000	2755	909	13.1	982	19.1	1048	25.1	1110	31.5	1168	38.1	1224	45.0	1278	51.9	1330	58.8	1380	66.0
36000	2917	953	14.8	1024	21.1	1088	27.5	1147	34.0	1205	40.9	1258	48.1	1310	55.5	1361	62.7	1410	70.1
38000	3079	998	16.7	1066	23.3	1128	30.0	1186	36.8	1240	43.9	1293	51.3	1344	59.0	1393	66.8	1441	74.4
40000	3241	1043	18.8	1109	25.7	1169	32.7	1225	39.8	1278	47.2	1330	54.8	1379	62.7	1426	70.8	1472	79.0
42000	3403	1089	21.0	1152	28.2	1210	35.5	1265	43.0	1317	50.6	1366	58.5	1414	66.6	1461	74.9	1505	83.5
44000	3565	1135	23.5	1195	30.9	1252	38.6	1305	46.4	1356	54.3	1403	62.4	1450	70.7	1496	79.3	1540	88.1
46000	3727	1180	26.1	1239	33.9	1294	41.9	1346	50.0	1395	58.2	1442	66.5	1487	75.1	1532	83.9		
48000	3889	1227	28.9	1284	37.0	1337	45.4	1387	53.8	1435	62.3	1481	70.9	1525	79.7				

RPM	% WOV	Inlet Sound Power, L _{wi} [dB ref 10 ⁻¹² watts]									
		1	2	3	4	5	6	7	8	9	L _{wiA}
450	100	81	86	76	69	71	62	58	53	76	
	80	79	83	72	64	62	56	53	49	71	
	60	79	82	70	62	59	55	52	48	69	
	50	81	79	69	62	60	56	53	49	68	
600	100	85	95	82	76	76	72	66	61	83	
	80	82	91	78	70	69	63	60	56	78	
	60	81	89	76	68	65	61	58	56	76	
	50	82	91	77	68	66	61	59	57	77	
850	100	88	96	97	86	84	81	76	72	91	
	80	87	95	96	82	78	73	70	67	89	
	60	85	92	91	78	74	70	67	66	85	
	50	86	95	92	78	74	70	68	67	86	
1200	100	94	97	102	95	94	89	86	82	99	
	80	90	94	100	91	89	83	78	76	95	
	60	88	91	98	88	85	78	76	75	92	
	50	88	94	102	88	84	78	77	76	95	
1560	100	99	103	107	103	100	97	93	89	106	
	80	94	99	104	100	95	91	86	82	102	
	60	92	97	101	98	92	86	82	81	99	
	50	92	99	105	99	91	86	83	82	101	

RPM	% WOV	Outlet Sound Power, L _{wo} [dB ref 10 ⁻¹² watts]									
		1	2	3	4	5	6	7	8	9	L _{woA}
450	100	79	85	80	79	77	70	66	56	81	
	80	78	84	76	75	72	66	61	54	77	
	60	79	81	74	74	71	63	60	54	75	
	50	80	79	73	73	71	62	59	55	75	
600	100	82	92	85	84	82	77	73	66	86	
	80	81	92	82	80	78	71	69	63	83	
	60	82	89	83	80	77	70	66	62	82	
	50	89	91	86	84	80	72	67	62	85	
850	100	85	94	98	94	90	86	83	77	96	
	80	85	92	96	91	85	81	78	74	93	
	60	86	92	94	88	83	79	76	71	90	
	50	89	96	94	89	85	79	76	71	91	
1200	100	94	98	105	103	100	94	91	87	105	
	80	92	95	103	99	95	89	85	82	101	
	60	95	97	101	96	92	86	83	79	98	
	50	95	100	103	96	91	86	82	78	99	
1560	100	98	104	108	110	106	102	98	95	111	
	80	97	101	106	107	102	97	92	89	108	
	60	99	103	105	104	99	94	90	86	105	
	50	99	105	108	105	99	94	89	85	106	

Performance certified is for installation type A: Free inlet, Free outlet. Power ratings (Bhp) do not include transmission losses. Performance ratings do not include the effects of appurtenances (accessories).

The sound power level ratings shown are in decibels, referred to 10⁻¹² watts calculated per AMCA International Standard 301. Values shown are for inlet L_{wi}, L_{wiA} and outlet L_{wo}, L_{woA} sound power levels for installation type A: Free inlet, Free outlet. The A-weighted sound ratings shown have been calculated per AMCA International Standard 301. Outlet ratings do not include the effects of duct end correction.

Plenum Size 44

QEP Class I	Maximum rpm 860
QEP Class II	Maximum rpm 1120
QEP Class III	Maximum rpm 1411

QEP Motor on Frame Limit	326T
Minimum Motor Size	3 [hp]
Wheel Diameter	44.50 [in.] 1130 [mm]
Peak Power	(rpm / 288) ³ [hp] (rpm / 318) ³ [kW]
Wheel Outlet Velocity	cfm / 15.1 [ft/min] m ³ /s / 8.88 [m/s]
Tip Speed	rpm x 11.7 [ft/min] rpm x 0.0592 [m/s]
% Wide Open Volume (%WOV)	cfm / (rpm x 0.554) [%] m ³ /hr / (rpm x 0.941) [%]

Imperial data — Metric data

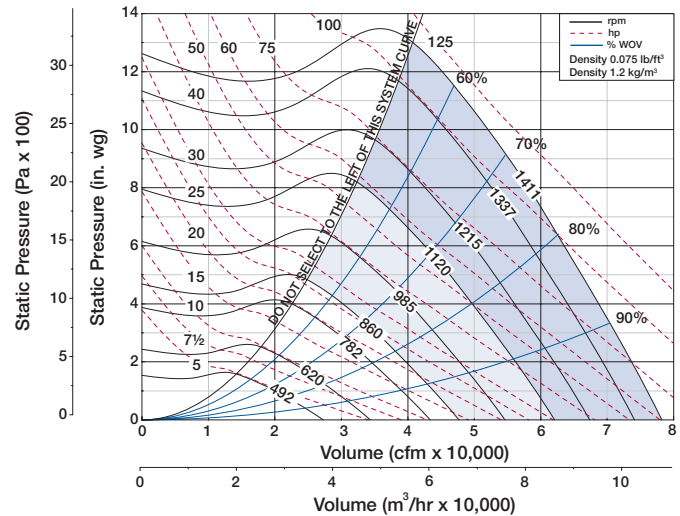

CFM	OV	STATIC PRESSURE (in. wg)																	
		1		2		3		4		5		6		7		8		9	
		RPM	BHP	RPM	BHP	RPM	BHP	RPM	BHP	RPM	BHP	RPM	BHP	RPM	BHP	RPM	BHP	RPM	BHP
30000	1988	638	8.54	718	14.0	790	19.9	857	26.0	919	32.3	980	38.9	1036	45.7				
33000	2186	684	10.2	761	16.0	829	22.3	892	29.0	953	35.7	1008	42.7	1064	49.9	1116	57.3		
36000	2385	732	12.0	805	18.3	869	25.0	930	32.1	987	39.4	1042	46.7	1093	54.3	1144	62.1	1193	70.1
39000	2584	780	14.1	849	20.9	911	27.9	969	35.4	1024	43.2	1076	51.1	1127	59.1	1174	67.2	1222	75.6
42000	2783	829	16.4	895	23.7	955	31.2	1010	39.0	1062	47.2	1113	55.7	1161	64.2	1208	72.7	1253	81.5
45000	2982	879	19.1	941	26.9	999	34.8	1052	43.0	1103	51.5	1151	60.4	1197	69.6	1243	78.6	1287	87.8
48000	3180	929	22.0	989	30.3	1044	38.8	1095	47.3	1143	56.2	1191	65.4	1235	74.9	1278	84.8	1321	94.4
51000	3379	979	25.3	1036	34.0	1089	43.0	1139	52.0	1186	61.3	1231	70.8	1274	80.7	1317	90.9	1357	101
54000	3578	1030	29.0	1085	38.1	1136	47.5	1184	57.2	1229	66.8	1272	76.7	1315	86.9	1356	97.4	1395	108
57000	3777	1081	33.0	1134	42.6	1183	52.5	1229	62.5	1273	72.7	1315	83.0	1356	93.5	1396	104		
60000	3976	1133	37.4	1183	47.4	1230	57.9	1275	68.3	1318	79.1	1359	89.7	1398	101				
63000	4174	1184	42.1	1232	52.7	1278	63.6	1322	74.6	1363	85.7	1403	96.9						

RPM	% WOV	Inlet Sound Power, L _{wi} [dB ref 10 ⁻¹² watts]									
		1	2	3	4	5	6	7	8	L _{wiA}	
400	100	83	85	75	71	70	62	58	52	75	
	80	81	82	71	64	62	56	53	48	70	
	60	81	81	69	62	59	55	52	48	68	
	50	80	77	68	62	59	56	53	48	67	
550	100	88	94	82	77	77	72	67	61	83	
	80	85	90	78	72	69	64	61	57	78	
	60	84	89	76	69	66	62	59	57	76	
	50	85	90	77	69	66	62	60	58	77	
800	100	90	98	97	87	85	82	78	74	93	
	80	90	97	96	83	79	75	72	69	90	
	60	88	94	91	80	75	71	69	67	86	
	50	89	97	92	79	75	72	69	68	87	
1100	100	96	99	102	96	94	90	87	82	100	
	80	92	96	100	92	89	83	79	77	96	
	60	89	93	98	89	85	79	77	76	93	
	50	90	97	101	89	84	79	78	77	95	
1411	100	101	104	108	104	100	97	93	90	106	
	80	96	101	105	100	95	91	86	83	102	
	60	94	98	103	98	92	87	83	81	99	
	50	94	101	107	99	91	87	84	83	101	

RPM	% WOV	Outlet Sound Power, L _{wo} [dB ref 10 ⁻¹² watts]									
		1	2	3	4	5	6	7	8	L _{woA}	
400	100	81	85	80	79	77	70	64	54	81	
	80	80	83	76	75	72	66	61	54	77	
	60	80	80	74	74	70	63	59	54	75	
	50	80	79	74	74	70	62	59	54	75	
550	100	85	92	86	85	82	78	73	66	87	
	80	84	92	83	81	78	72	69	63	84	
	60	85	90	84	81	77	70	67	62	83	
	50	90	92	87	85	80	73	68	63	86	
800	100	88	96	99	95	91	87	84	79	97	
	80	87	95	98	92	87	82	80	75	94	
	60	89	95	95	90	85	81	77	72	92	
	50	92	98	95	91	86	81	77	72	93	
1100	100	96	100	106	104	100	95	92	88	105	
	80	94	98	104	100	96	90	86	83	101	
	60	96	99	102	97	92	87	83	79	99	
	50	97	102	103	97	92	87	83	79	99	
1411	100	100	105	110	110	102	98	95	111		
	80	99	103	107	107	103	97	92	108		
	60	101	104	107	104	99	94	90	105		
	50	101	106	110	105	99	94	90	106		

Performance certified is for installation type A: Free inlet, Free outlet. Power ratings (Bhp) do not include transmission losses. Performance ratings do not include the effects of appurtenances (accessories).

The sound power level ratings shown are in decibels, referred to 10⁻¹² watts calculated per AMCA International Standard 301. Values shown are for inlet L_{wi}, L_{wiA} and outlet L_{wo}, L_{woA} sound power levels for installation type A: Free inlet, Free outlet. The A-weighted sound ratings shown have been calculated per AMCA International Standard 301. Outlet ratings do not include the effects of duct end correction.

Plenum Size 49

QEP Class I	Maximum rpm 780
QEP Class II	Maximum rpm 1017
QEP Class III	Maximum rpm 1281

QEP Motor on Frame Limit	326T
Minimum Motor Size	3 [hp]
Wheel Diameter	49.00 [in.] 1245 [mm]
Peak Power	(rpm / 245) ³ [hp] (rpm / 270) ³ [kW]
Wheel Outlet Velocity	cfm / 18.4 [ft/min] m ³ /s / 10.9 [m/s]
Tip Speed	rpm x 12.8 [ft/min] rpm x 0.0652 [m/s]
% Wide Open Volume (%WOV)	cfm / (rpm x 0.740) [%] m ³ /hr / (rpm x 1.257) [%]

Imperial data — Metric data

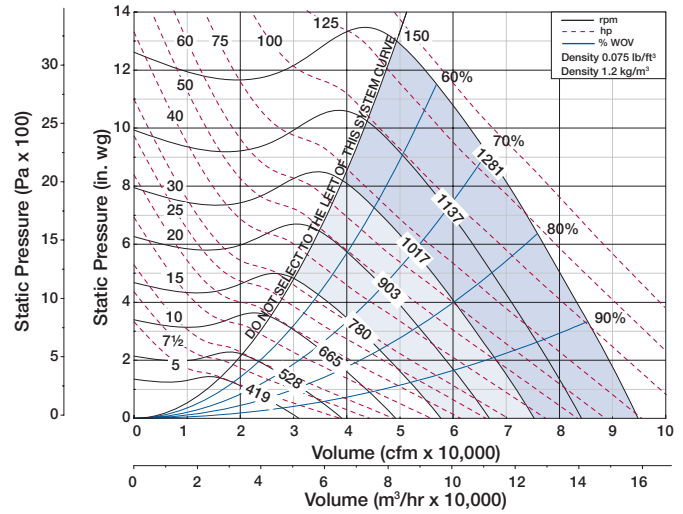

CFM	OV	STATIC PRESSURE (in. wg)																	
		1		2		3		4		5		6		7		8		9	
		RPM	BHP	RPM	BHP	RPM	BHP	RPM	BHP	RPM	BHP	RPM	BHP	RPM	BHP	RPM	BHP	RPM	BHP
36000	1968	575	10.2	648	16.7	714	23.9	775	31.2	832	38.8	887	46.7						
39000	2132	609	11.7	680	18.7	743	26.2	801	34.1	856	42.1	909	50.4	959	59.0	1007	67.9		
42000	2296	645	13.5	713	20.9	773	28.8	829	37.2	882	45.7	932	54.4	980	63.4	1028	72.6	1072	82.1
45000	2460	681	15.4	746	23.4	803	31.6	858	40.3	908	49.5	958	58.6	1004	67.9	1049	77.6	1093	87.4
48000	2624	717	17.6	779	26.0	835	34.6	888	43.7	937	53.3	984	63.1	1029	72.8	1072	82.8	1114	93.1
51000	2788	754	20.0	814	28.9	868	37.9	918	47.4	966	57.3	1011	67.6	1055	78.0	1098	88.3	1138	99.0
54000	2952	791	22.6	848	31.9	901	41.5	949	51.3	996	61.6	1040	72.3	1082	83.4	1124	94.2	1164	105
57000	3116	829	25.5	884	35.3	934	45.4	982	55.6	1026	66.2	1069	77.2	1110	88.7	1150	100	1189	112
60000	3280	866	28.6	919	38.9	968	49.5	1014	60.1	1057	71.1	1099	82.5	1139	94.3	1178	106	1215	119
63000	3444	904	32.0	955	42.8	1003	53.8	1047	65.0	1090	76.4	1129	88.1	1170	100	1207	113	1244	126
66000	3608	942	35.8	992	47.0	1038	58.5	1081	70.2	1122	81.9	1161	94.0	1199	107	1236	119	1272	133
69000	3772	980	39.8	1028	51.4	1073	63.5	1115	75.6	1155	87.9	1193	100	1230	113	1267	126		

RPM	% WOV	Inlet Sound Power, L _{Wi} [dB ref 10 ⁻¹² watts]									
		1	2	3	4	5	6	7	8	L _{WiA}	
350	100	85	83	73	71	68	61	57	51	74	
	80	82	79	69	64	60	56	52	48	69	
	60	82	78	67	62	58	54	51	47	67	
	50	79	76	67	62	58	55	52	48	66	
500	100	91	93	82	78	77	72	67	61	83	
	80	88	89	77	72	69	65	61	57	77	
	60	86	88	75	69	66	62	59	57	75	
	50	87	89	76	69	66	63	61	58	76	
700	100	92	99	95	87	85	81	77	73	92	
	80	91	99	93	83	78	74	71	68	88	
	60	90	94	88	79	74	71	69	67	84	
	50	92	96	89	79	74	71	69	68	85	
1000	100	97	101	102	97	95	91	87	83	100	
	80	93	98	100	93	89	84	79	77	96	
	60	91	95	97	90	85	79	78	77	93	
	50	92	99	100	89	84	80	79	78	94	
1281	100	102	106	109	104	101	97	94	90	107	
	80	98	102	107	100	96	91	86	83	103	
	60	95	100	104	98	92	87	84	82	100	
	50	96	103	108	99	91	87	84	83	102	

RPM	% WOV	Outlet Sound Power, L _{Wo} [dB ref 10 ⁻¹² watts]									
		1	2	3	4	5	6	7	8	L _{WoA}	
350	100	83	84	80	79	75	69	62	52	80	
	80	82	81	76	75	70	65	59	52	76	
	60	80	78	74	74	68	62	58	53	74	
	50	79	77	74	74	68	61	58	53	74	
500	100	87	92	87	85	82	78	73	66	88	
	80	87	91	84	82	78	73	69	63	84	
	60	87	89	84	81	77	71	67	63	83	
	50	92	92	88	85	80	73	68	63	86	
700	100	90	98	99	94	90	87	83	78	97	
	80	88	97	96	91	86	82	79	74	93	
	60	90	95	94	89	84	80	76	71	91	
	50	94	96	94	90	85	80	76	71	92	
1000	100	97	102	107	104	100	95	92	89	106	
	80	95	100	104	101	96	90	86	83	102	
	60	97	100	102	97	92	87	84	80	99	
	50	99	103	103	97	92	87	83	79	99	
1281	100	102	107	111	111	107	102	98	96	112	
	80	100	104	108	107	103	97	93	90	108	
	60	102	105	108	104	99	95	90	87	106	
	50	103	108	111	105	99	94	90	86	107	

Performance certified is for installation type A: Free inlet, Free outlet. Power ratings (Bhp) do not include transmission losses. Performance ratings do not include the effects of appurtenances (accessories).

The sound power level ratings shown are in decibels, referred to 10⁻¹² watts calculated per AMCA International Standard 301. Values shown are for inlet L_{Wi}, L_{WiA} and outlet L_{Wo}, L_{WoA} sound power levels for installation type A: Free inlet, Free outlet. The A-weighted sound ratings shown have been calculated per AMCA International Standard 301. Outlet ratings do not include the effects of duct end correction.

Plenum Size 54

QEP Class I	Maximum rpm	704
QEP Class II	Maximum rpm	918
QEP Class III	Maximum rpm	1171

QEP Motor on Frame Limit	364T
Minimum Motor Size	5 [hp]
Wheel Diameter	54.25 [in.] 1378 [mm]
Peak Power	(rpm / 207) ³ [hp] (rpm / 228) ³ [kW]
Wheel Outlet Velocity	cfm / 22.4 [ft/min] m ³ /s / 13.2 [m/s]
Tip Speed	rpm x 14.2 [ft/min] rpm x 0.0721 [m/s]
% Wide Open Volume (%WOV)	cfm / (rpm x 1.00) [%] m ³ /hr / (rpm x 1.699) [%]

Imperial data — Metric data

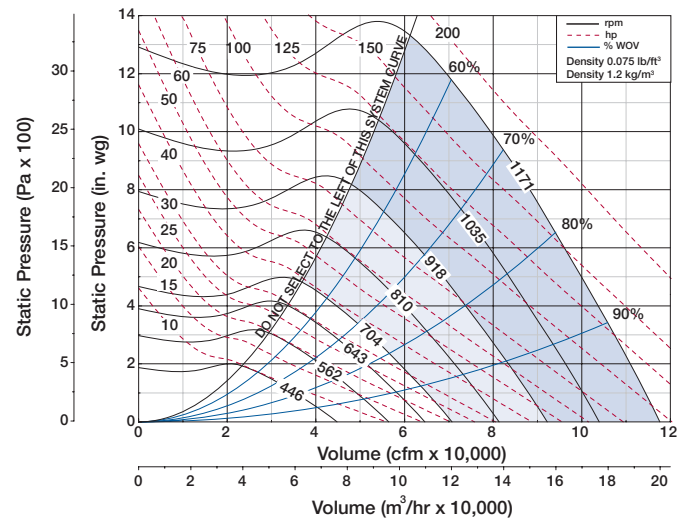

CFM	OV	STATIC PRESSURE (in. wg)																	
		1		2		3		4		5		6		7		8		9	
		RPM	BHP	RPM	BHP	RPM	BHP	RPM	BHP	RPM	BHP	RPM	BHP	RPM	BHP	RPM	BHP	RPM	BHP
40000	1784	484	10.6	554	18.0	618	26.1	675	34.5	730	43.3								
45000	2007	526	12.9	592	21.0	651	29.9	706	39.0	756	48.5	806	58.3	852	68.5				
50000	2230	570	15.7	632	24.5	687	34.0	738	44.1	787	54.2	833	64.6	878	75.5	920	86.6		
55000	2453	614	18.8	672	28.5	724	38.5	773	49.3	819	60.5	864	71.6	906	83.0	947	94.8	986	107
60000	2676	658	22.4	714	33.0	764	43.7	810	55.0	854	66.8	896	79.1	937	91.2	976	104	1012	116
65000	2899	704	26.6	756	37.9	804	49.4	848	61.3	891	73.8	931	86.7	969	100	1007	113	1043	126
70000	3122	750	31.3	799	43.4	845	55.8	888	68.3	927	81.3	966	94.9	1004	109	1039	123	1075	137
75000	3345	796	36.7	843	49.6	887	62.7	928	76.0	967	89.6	1004	104	1039	118	1074	133	1108	149
80000	3568	842	42.7	888	56.3	929	70.2	969	84.5	1006	98.7	1042	113	1077	129	1110	144	1143	160
85000	3791	889	49.4	932	63.7	973	78.5	1011	93.5	1047	109	1081	124	1114	140	1147	156		
90000	4014	937	56.8	978	71.9	1016	87.5	1053	103	1088	119	1121	135	1154	152				
95000	4237	985	65.0	1023	80.9	1060	97.2	1096	114	1130	131								

RPM	% WOV	Inlet Sound Power, L _{wi} [dB ref 10 ⁻¹² watts]									
		1	2	3	4	5	6	7	8	L _{wiA}	
300	100	86	80	71	72	66	60	55	50	73	
	80	83	77	67	64	59	55	51	47	67	
	60	83	75	65	61	57	53	50	46	65	
	50	78	73	65	61	57	55	51	46	65	
450	100	93	92	81	79	78	72	67	61	83	
	80	90	88	77	73	69	65	61	57	77	
	60	89	86	75	70	66	62	60	58	75	
	50	90	88	75	70	66	63	61	59	76	
650	100	95	102	95	88	86	82	78	74	93	
	80	94	101	92	84	79	75	72	69	90	
	60	92	96	88	80	75	72	70	68	85	
	50	95	98	89	80	76	72	71	69	86	
900	100	99	103	102	98	95	91	87	83	100	
	80	94	100	99	93	89	84	80	78	96	
	60	92	97	96	90	85	80	78	77	93	
	50	94	101	99	89	84	81	79	78	94	
1160	100	104	107	110	105	101	98	94	90	107	
	80	99	104	107	101	96	91	87	83	103	
	60	97	102	104	98	92	87	84	83	100	
	50	98	105	108	98	91	87	85	84	102	

RPM	% WOV	Outlet Sound Power, L _{wo} [dB ref 10 ⁻¹² watts]									
		1	2	3	4	5	6	7	8	L _{woA}	
300	100	85	82	79	79	73	68	60	50	79	
	80	84	79	76	74	68	64	58	51	75	
	60	80	76	74	73	66	62	57	52	73	
	50	79	75	74	73	65	61	57	52	73	
450	100	90	91	87	86	82	79	73	66	88	
	80	90	90	84	83	77	73	69	63	84	
	60	89	89	84	82	76	71	67	63	83	
	50	93	91	88	86	79	73	68	63	86	
650	100	92	101	100	96	91	88	84	79	98	
	80	91	99	97	92	87	83	80	75	94	
	60	93	97	95	90	85	81	77	72	92	
	50	97	97	95	91	86	81	77	72	93	
900	100	99	105	107	105	100	96	92	89	106	
	80	97	102	104	101	95	90	87	83	102	
	60	99	102	102	97	92	88	84	80	99	
	50	100	105	103	97	92	87	83	79	99	
1160	100	104	108	112	111	107	102	99	96	112	
	80	102	106	110	108	103	97	93	90	109	
	60	104	107	109	105	100	95	91	87	106	
	50	105	109	111	105	99	95	90	86	107	

Performance certified is for installation type A: Free inlet, Free outlet. Power ratings (Bhp) do not include transmission losses. Performance ratings do not include the effects of appurtenances (accessories).

The sound power level ratings shown are in decibels, referred to 10⁻¹² watts calculated per AMCA International Standard 301. Values shown are for inlet L_{wi}, L_{wiA} and outlet L_{wo}, L_{woA} sound power levels for installation type A: Free inlet, Free outlet. The A-weighted sound ratings shown have been calculated per AMCA International Standard 301. Outlet ratings do not include the effects of duct end correction.

Plenum Size 60

QEP Class I	Maximum rpm	637
QEP Class II	Maximum rpm	830
QEP Class III	Maximum rpm	1046

QEP Motor on Frame Limit	365T
Minimum Motor Size	5 [hp]
Wheel Diameter	60.00 [in.] 1524 [mm]
Peak Power	(rpm / 175) ³ [hp] (rpm / 193) ³ [kW]
Wheel Outlet Velocity	cfm / 27.4 [ft/min] m ³ /s / 16.1 [m/s]
Tip Speed	rpm x 15.7 [ft/min] rpm x 0.0798 [m/s]
% Wide Open Volume (%WOV)	cfm / (rpm x 1.36) [%] m ³ /hr / (rpm x 2.311) [%]

Imperial data — Metric data

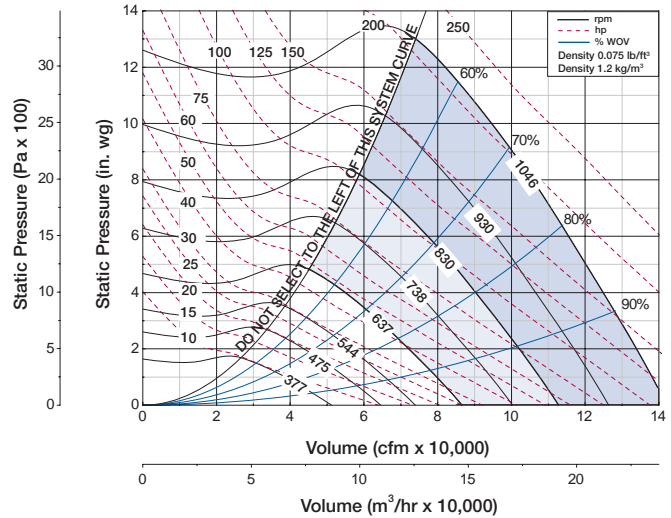

CFM	OV	STATIC PRESSURE (in. wg)																	
		1		2		3		4		5		6		7		8		9	
		RPM	BHP	RPM	BHP	RPM	BHP	RPM	BHP	RPM	BHP	RPM	BHP	RPM	BHP	RPM	BHP	RPM	BHP
55000	2005	476	15.8	535	25.7	588	36.6	638	47.7	683	59.2	729	71.3	770	83.7				
60000	2187	507	18.5	564	29.1	614	40.6	661	52.8	706	64.9	747	77.6	789	90.6	828	104		
65000	2369	540	21.5	594	33.0	642	45.0	687	57.8	730	71.0	770	84.3	808	98.0	847	112	883	127
70000	2551	573	24.9	624	37.3	671	49.9	714	63.3	754	77.4	794	91.6	831	106	866	121	902	136
75000	2734	606	28.7	655	41.8	700	55.2	741	69.2	781	83.9	818	99.3	855	114	889	130	923	146
80000	2916	640	33.0	687	46.9	730	61.1	770	75.6	808	90.9	844	107	878	123	913	139	946	156
85000	3098	674	37.7	719	52.4	760	67.5	799	82.7	835	98.5	870	115	904	132	937	150	969	167
90000	3281	708	42.9	751	58.4	791	74.2	829	90.2	864	107	898	124	930	141	962	160	993	178
95000	3463	742	48.7	784	64.9	822	81.5	859	98.4	893	116	925	133	958	151	988	170	1018	189
100000	3645	777	55.0	817	71.9	854	89.4	889	107	923	125	954	143	985	162	1015	181	1044	201
105000	3827	811	61.9	850	79.6	886	97.8	920	116	953	135	984	154	1013	173	1043	193		
110000	4010	846	69.3	883	87.8	918	107	951	126	983	146	1013	165	1042	185				

RPM	% WOV	Inlet Sound Power, L _{Wi} [dB ref 10 ⁻¹² watts]									
		1	2	3	4	5	6	7	8	L _{WiA}	
300	100	90	83	74	75	69	63	58	53	76	
	80	87	80	70	67	62	58	54	50	70	
	60	86	78	68	64	60	57	53	49	68	
	50	82	76	68	64	60	58	54	49	68	
400	100	96	90	80	80	77	72	66	61	83	
	80	92	86	76	74	68	65	61	57	76	
	60	91	84	73	70	66	62	60	58	74	
	50	92	86	74	70	66	63	61	59	75	
600	100	97	103	94	89	87	83	79	75	94	
	80	96	103	92	85	80	76	73	70	91	
	60	95	98	88	81	76	73	71	70	86	
	50	97	99	88	81	76	73	72	71	87	
800	100	99	104	101	98	94	91	87	83	100	
	80	95	102	98	94	89	83	80	78	95	
	60	93	99	95	90	84	80	79	78	92	
	50	95	103	96	89	84	81	80	79	93	
1046	100	105	109	109	105	101	98	94	91	107	
	80	101	106	107	101	96	91	87	84	103	
	60	98	103	104	98	92	87	85	83	100	
	50	100	106	107	98	91	88	86	85	102	

RPM	% WOV	Outlet Sound Power, L _{Wo} [dB ref 10 ⁻¹² watts]									
		1	2	3	4	5	6	7	8	L _{WoA}	
300	100	88	85	82	82	76	71	63	53	82	
	80	87	82	79	77	71	67	61	54	78	
	60	84	79	77	76	69	65	60	55	76	
	50	82	78	77	76	68	64	60	55	76	
400	100	93	90	87	87	82	79	72	65	88	
	80	93	88	84	83	76	74	69	63	84	
	60	91	88	84	82	75	71	67	63	83	
	50	94	91	88	86	78	73	68	62	86	
600	100	94	103	100	96	92	89	85	80	99	
	80	93	101	98	93	87	84	80	76	95	
	60	95	98	96	91	86	82	78	73	93	
	50	100	99	96	92	86	82	78	73	94	
800	100	100	106	107	105	99	96	92	89	106	
	80	97	104	104	101	95	90	87	83	102	
	60	99	103	102	97	92	88	84	79	99	
	50	102	106	102	97	92	87	83	79	99	
1046	100	105	110	113	111	107	103	99	97	113	
	80	103	107	111	108	103	97	94	90	109	
	60	105	108	109	105	100	95	91	87	106	
	50	106	110	111	105	99	95	91	87	107	

Performance certified is for installation type A: Free inlet, Free outlet. Power ratings (Bhp) do not include transmission losses. Performance ratings do not include the effects of appurtenances (accessories).

The sound power level ratings shown are in decibels, referred to 10⁻¹² watts calculated per AMCA International Standard 301. Values shown are for inlet L_{Wi}, L_{WiA} and outlet L_{Wo}, L_{WoA} sound power levels for installation type A: Free inlet, Free outlet. The A-weighted sound ratings shown have been calculated per AMCA International Standard 301. Outlet ratings do not include the effects of duct end correction.

Plenum Size 66

QEP Class I	Maximum rpm	579
QEP Class II	Maximum rpm	755
QEP Class III	Maximum rpm	951

QEP Motor on Frame Limit	365T
Minimum Motor Size	7½ [hp]
Wheel Diameter	66.00 [in.] 1676 [mm]
Peak Power	(rpm / 149) ³ [hp] (rpm / 164) ³ [kW]
Wheel Outlet Velocity	cfm / 33.2 [ft/min] m ³ /s / 19.5 [m/s]
Tip Speed	rpm x 17.3 [ft/min] rpm x 0.0878 [m/s]
% Wide Open Volume (%WOV)	cfm / (rpm x 1.81) [%] m ³ /hr / (rpm x 3.075) [%]

Imperial data — Metric data

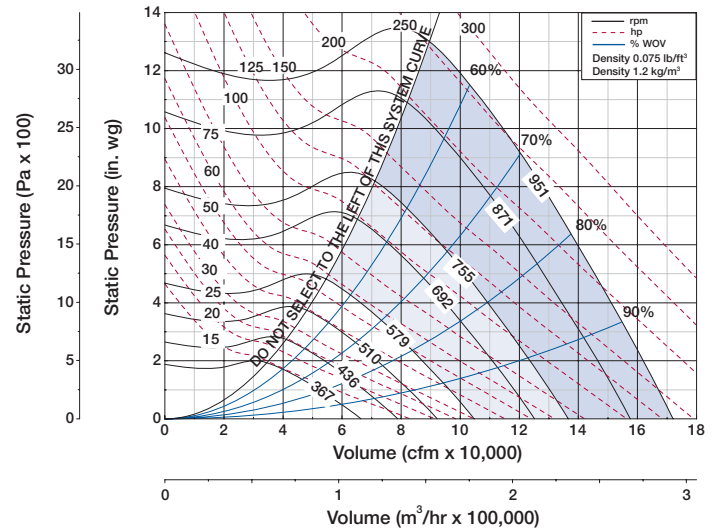

CFM	OV	STATIC PRESSURE (in. wg)																	
		1		2		3		4		5		6		7		8		9	
		RPM	BHP	RPM	BHP	RPM	BHP	RPM	BHP	RPM	BHP	RPM	BHP	RPM	BHP	RPM	BHP	RPM	BHP
70000	2109	449	20.9	502	33.4	548	47.0	592	61.2	633	75.5	672	90.5	710	106				
75000	2259	473	23.8	524	37.1	569	51.2	610	66.3	650	81.4	688	97.0	724	113	759	130	793	147
80000	2410	497	26.9	546	41.0	589	55.7	630	71.4	668	87.7	705	104	739	121	774	138	807	156
85000	2561	522	30.4	569	45.3	611	60.6	650	76.9	687	94.0	723	111	757	129	789	147	821	165
90000	2711	547	34.2	592	49.9	633	66.0	671	82.8	707	101	740	119	774	137	806	156	836	175
95000	2862	572	38.3	616	54.8	655	71.7	692	89.1	726	107	760	127	792	146	823	165	853	185
100000	3012	598	42.9	640	60.2	678	77.9	714	95.9	748	115	780	134	811	155	841	175	871	195
105000	3163	623	47.8	664	65.9	701	84.5	736	103	768	123	800	143	830	164	859	185	888	206
110000	3314	649	53.2	688	72.1	724	91.3	758	111	790	131	821	152	850	173	879	195	906	218
115000	3464	675	59.0	713	78.6	748	98.7	781	119	812	140	841	161	871	183	899	206	926	229
120000	3615	701	65.2	737	85.6	772	107	804	128	834	149	863	171	891	194	919	217	945	241
125000	3766	727	72.0	762	93.0	796	115	827	137	857	159	885	182	912	205	940	229		

RPM	% WOV	Inlet Sound Power, L _{wi} [dB ref 10 ⁻¹² watts]									
		1	2	3	4	5	6	7	8	L _{wiA}	
250	100	90	79	71	75	65	61	56	50	75	
	80	86	75	66	65	59	56	52	47	68	
	60	86	74	64	62	57	55	51	47	66	
	50	82	72	65	63	58	56	52	47	66	
350	100	98	87	79	81	77	71	65	60	82	
	80	94	83	74	73	67	65	60	56	76	
	60	92	81	71	70	65	62	60	58	73	
	50	94	83	71	70	65	63	61	59	74	
500	100	98	103	90	88	86	81	77	73	92	
	80	96	103	86	83	78	74	71	68	89	
	60	95	97	83	79	74	71	70	68	85	
	50	98	99	83	78	74	72	70	69	86	
700	100	99	105	99	98	93	90	86	82	100	
	80	95	103	95	93	87	82	80	77	95	
	60	93	101	93	90	82	79	78	77	92	
	50	96	105	93	88	82	80	80	79	93	
951	100	106	110	109	105	102	98	95	91	108	
	80	102	107	106	101	97	91	87	84	103	
	60	100	105	104	98	92	87	85	84	100	
	50	101	108	106	97	92	88	86	85	101	

RPM	% WOV	Outlet Sound Power, L _{wO} [dB ref 10 ⁻¹² watts]									
		1	2	3	4	5	6	7	8	L _{wO} A	
250	100	88	82	81	81	73	69	59	49	81	
	80	87	78	77	76	69	65	58	51	76	
	60	83	76	76	75	66	63	58	52	75	
	50	82	75	76	75	64	62	58	53	74	
350	100	95	88	87	86	81	78	71	64	87	
	80	95	86	84	83	75	73	67	62	83	
	60	92	87	84	82	74	70	66	62	82	
	50	94	89	88	86	77	72	67	61	86	
500	100	95	103	98	94	90	87	82	77	97	
	80	93	101	95	90	85	83	78	74	93	
	60	95	98	93	88	83	81	75	70	91	
	50	101	98	94	90	84	81	76	71	92	
700	100	100	108	107	104	98	95	92	88	105	
	80	97	105	104	100	93	89	86	82	101	
	60	99	104	100	97	91	87	83	79	98	
	50	102	106	101	96	90	87	82	78	98	
951	100	106	111	114	112	107	103	100	97	113	
	80	104	109	112	108	103	98	94	91	109	
	60	106	109	109	105	100	95	91	88	107	
	50	108	112	111	105	99	95	91	87	107	

Performance certified is for installation type A: Free inlet, Free outlet. Power ratings (Bhp) do not include transmission losses. Performance ratings do not include the effects of appurtenances (accessories).

The sound power level ratings shown are in decibels, referred to 10⁻¹² watts calculated per AMCA International Standard 301. Values shown are for inlet L_{wi}, L_{wiA} and outlet L_{wO}, L_{wOA} sound power levels for installation type A: Free inlet, Free outlet. The A-weighted sound ratings shown have been calculated per AMCA International Standard 301. Outlet ratings do not include the effects of duct end correction.

Plenum Size 73

QEP Class I	Maximum rpm	523
QEP Class II	Maximum rpm	683
QEP Class III	Maximum rpm	860

QEP Motor on Frame Limit	365T
Minimum Motor Size	7½ [hp]
Wheel Diameter	73.00 [in.] 1854 [mm]
Peak Power	(rpm / 126) ³ [hp] (rpm / 139) ³ [kW]
Wheel Outlet Velocity	cfm / 40.6 [ft/min] m ³ /s / 23.9 [m/s]
Tip Speed	rpm x 19.1 [ft/min] rpm x 0.0971 [m/s]
% Wide Open Volume (%WOV)	cfm / (rpm x 2.45) [%] m ³ /hr / (rpm x 4.163) [%]

Imperial data — Metric data

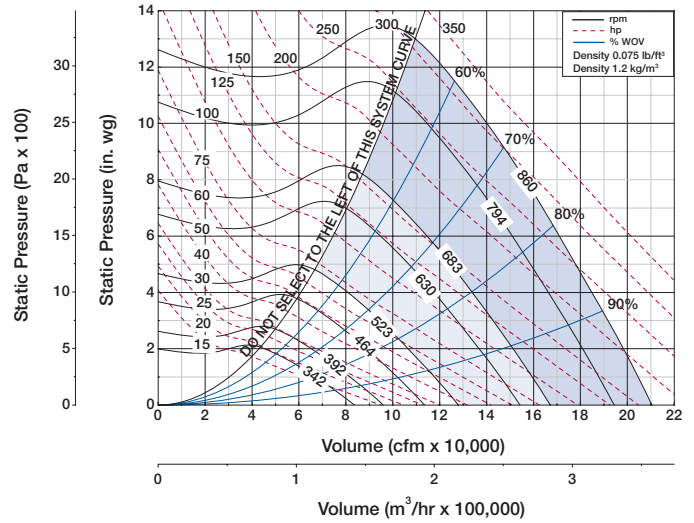

CFM	OV	STATIC PRESSURE (in. wg)																	
		1		2		3		4		5		6		7		8		9	
		RPM	BHP	RPM	BHP	RPM	BHP	RPM	BHP	RPM	BHP	RPM	BHP	RPM	BHP	RPM	BHP	RPM	BHP
90000	2216	421	28.0	468	44.0	508	61.1	547	79.3	583	97.5	617	116	651	136	683	156		
95000	2339	439	31.1	484	47.9	524	65.5	561	84.3	596	104	630	123	661	143	694	164	723	185
100000	2463	457	34.3	501	52.0	540	70.2	576	89.6	610	110	643	130	674	151	704	172	734	194
105000	2586	476	37.9	518	56.4	556	75.2	590	95.3	624	116	656	138	687	159	716	181	745	204
110000	2709	494	41.7	535	60.9	572	80.6	606	101	638	123	669	145	700	167	728	190	756	213
115000	2832	513	45.8	552	65.8	589	86.3	622	108	653	130	683	153	713	176	741	200	768	223
120000	2955	532	50.3	570	71.1	605	92.4	638	114	669	137	698	161	726	185	754	209	781	234
125000	3078	550	55.0	588	76.6	622	98.8	654	121	684	145	713	169	741	194	767	220	794	245
130000	3201	569	60.1	606	82.5	639	105	670	129	700	153	728	177	755	203	781	230	807	256
135000	3325	588	65.5	624	88.7	656	112	687	136	716	161	743	186	770	213	796	240	820	268
140000	3448	607	71.3	642	95.2	674	120	704	145	732	170	759	196	786	223	810	251	835	279
145000	3571	627	77.5	660	102	691	127	720	153	748	179	775	206	801	233	825	262	849	291

RPM	% WOV	Inlet Sound Power, L _{wi} [dB ref 10 ⁻¹² watts]									
		1	2	3	4	5	6	7	8	L _{wiA}	
250	100	93	83	74	78	68	64	59	53	78	
	80	90	79	69	68	62	59	55	50	71	
	60	89	77	67	65	61	58	54	50	69	
	50	85	76	68	66	61	59	55	50	69	
300	100	97	85	79	80	75	69	64	59	81	
	80	93	81	73	72	66	63	59	55	74	
	60	92	79	71	69	64	61	59	57	72	
	50	93	80	71	69	64	62	60	58	73	
450	100	99	102	90	88	86	81	77	73	92	
	80	98	101	86	83	78	75	72	69	88	
	60	96	96	83	79	74	72	70	69	84	
	50	99	97	83	79	75	72	71	70	85	
600	100	100	105	98	97	92	89	85	80	99	
	80	96	103	94	92	86	81	79	76	94	
	60	94	101	91	88	81	79	78	77	91	
	50	97	105	91	87	81	80	79	78	92	
860	100	107	111	109	105	102	99	95	91	108	
	80	103	109	106	101	97	91	88	84	103	
	60	101	106	104	98	92	88	86	84	100	
	50	103	110	106	97	92	88	87	86	101	

RPM	% WOV	Outlet Sound Power, L _{wo} [dB ref 10 ⁻¹² watts]									
		1	2	3	4	5	6	7	8	L _{woA}	
250	100	91	85	84	84	76	72	62	52	84	
	80	90	81	80	79	72	68	61	54	79	
	60	87	79	79	78	69	66	61	55	78	
	50	86	78	79	78	67	65	61	56	77	
300	100	95	88	87	85	80	76	69	62	86	
	80	95	85	83	81	74	72	66	60	82	
	60	92	86	83	80	73	69	65	61	81	
	50	94	89	87	83	75	70	65	60	84	
450	100	97	103	98	95	90	87	82	77	97	
	80	95	101	95	90	85	83	78	74	93	
	60	96	98	93	88	84	81	75	70	91	
	50	101	99	94	90	84	81	76	71	92	
600	100	101	108	106	103	97	94	91	87	104	
	80	98	106	102	99	92	88	85	81	100	
	60	100	104	99	95	89	86	82	77	97	
	50	103	106	99	95	89	85	81	77	97	
860	100	108	113	115	112	108	103	100	97	114	
	80	106	110	113	108	103	98	94	91	110	
	60	108	110	110	105	100	95	92	88	107	
	50	109	113	111	104	100	95	91	87	107	

Performance certified is for installation type A: Free inlet, Free outlet. Power ratings (Bhp) do not include transmission losses. Performance ratings do not include the effects of appurtenances (accessories).

The sound power level ratings shown are in decibels, referred to 10⁻¹² watts calculated per AMCA International Standard 301. Values shown are for inlet L_{wi}, L_{wiA} and outlet L_{wo}, L_{woA} sound power levels for installation type A: Free inlet, Free outlet. The A-weighted sound ratings shown have been calculated per AMCA International Standard 301. Outlet ratings do not include the effects of duct end correction.

For additional dimensional data, including QEP Arrangement 4, please refer to the CAPS program.

QEM Arrangement 9 - Horizontal, Motor on Frame, Mounted on Side

Size	A	B	C	D	E	F	G	H	Motor Frame Sizes		Weight (lbs)
									Min	Max	
12	19.50	20.13	23.50	22.75	36.75	3.25	13.00	22.75	56	184T	120
15	19.50	20.13	23.50	22.75	36.75	3.25	13.00	22.75	56	184T	120
16	21.00	21.25	24.63	24.75	39.75	3.75	14.25	24.75	56	215T	140
18	22.75	23.00	27.63	26.13	41.25	3.38	14.75	26.13	56	215T	150
20	24.50	25.13	29.75	27.50	44.25	3.00	15.25	27.50	56	215T	160
22	26.75	27.25	31.25	29.13	46.75	2.38	15.75	29.13	56	256T	200
24	29.00	28.13	32.13	32.25	49.00	3.25	17.75	32.25	56	256T	240
27	31.50	31.63	36.25	34.50	54.25	3.00	18.75	34.50	56	256T	315
30	34.50	33.94	38.56	38.13	57.50	3.63	20.88	38.13	56	256T	360
33	37.50	38.50	43.75	41.13	62.00	3.63	22.38	41.13	56	286T	455
36	41.00	42.00	47.25	44.75	64.75	3.75	24.25	44.75	143T	286T	570

Dimensions shown are in inches.

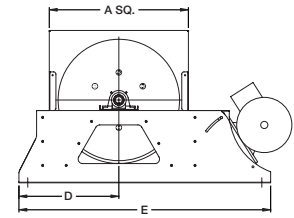

NOTE: MOTOR ON LEFT IS MIRROR IMAGE

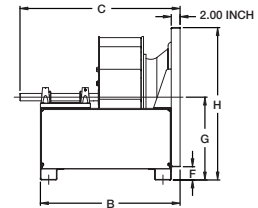

QEM Arrangement 4 - Horizontal, Direct Drive

Size	A	B	C	D	E	F	G	H	Motor Frame Sizes		Weight (lbs)
									Min	Max	
15	19.50	21.88	29.13	19.50	13.00	22.75	22.50	3.25	143T	184T	65
16	21.00	22.63	30.19	21.00	14.25	24.75	24.00	3.75	143T	184T	80
18	22.75	25.75	32.31	22.75	14.75	26.13	25.75	3.38	143T	215T	90
20	24.50	27.00	33.81	24.50	15.25	27.50	27.50	3.00	143T	215T	100
22	26.75	32.25	39.06	26.75	15.75	29.13	29.75	2.38	143T	256T	130
24	29.00	33.25	40.56	29.00	17.75	32.25	32.00	3.25	143T	256T	155
27	31.50	34.88	42.06	31.50	18.75	34.50	34.50	3.00	182T	256T	200
30	34.50	39.38	46.81	34.50	20.88	38.13	37.50	3.63	213T	286T	245
33	37.50	40.75	47.56	37.50	22.38	41.13	40.50	3.63	215T	286T	300
36	41.00	42.75	49.63	41.00	24.25	44.75	44.00	3.75	254T	286T	390

Dimensions shown are in inches.

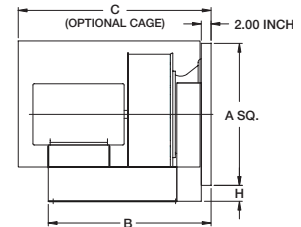
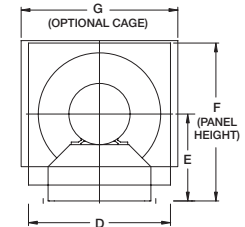

QEP Arrangement 1 - Horizontal, Motor off Frame

Size	A	A / 2	B	C			D	Weight (lbs)		
				I	II	III		I	II	III
12	22.75	11.38	22.88	25.63	26.25	N/A	15.88	85	90	N/A
15	22.75	11.38	22.88	25.63	26.25	26.88	15.88	85	90	100
16	24.50	12.25	24.25	27.00	27.63	28.25	17.50	100	110	110
18	27.50	13.75	26.75	30.13	31.38	31.38	19.28	120	130	130
20	29.50	14.75	29.13	32.50	33.75	33.75	21.13	140	160	170
22	31.50	15.75	32.13	35.50	36.13	37.38	23.00	170	200	220
24	35.50	17.75	34.88	38.25	38.88	40.13	25.88	230	240	260
27	37.50	18.75	37.88	41.88	42.50	43.13	28.50	260	270	290
30	41.75	20.88	41.50	45.50	46.13	47.38	31.75	330	350	420
33	44.75	22.38	45.38	49.38	50.63	51.25	34.88	360	380	460
36	48.50	24.25	49.13	53.13	54.38	56.38	38.50	400	470	510
40	52.50	26.25	53.88	58.50	59.13	61.13	42.00	490	570	600
44	58.00	29.00	59.50	64.13	65.38	68.00	46.50	570	690	730
49	62.50	31.25	64.88	70.13	70.75	73.38	51.00	780	830	950
54	68.00	34.00	71.00	76.25	78.25	79.50	56.50	970	1100	1300
60	75.00	37.50	78.38	83.63	86.88	88.88	62.50	1400	1500	1500
66	81.50	40.75	85.00	90.88	95.50	95.50	69.00	1700	1700	1700
73	92.00	46.00	93.88	99.75	102.38	104.38	76.00	2000	2000	2100

Dimensions shown are in inches.

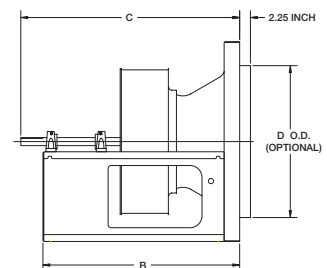
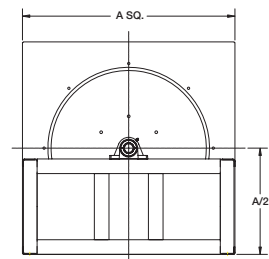

QEP Arrangement 1 - Horizontal, Motor on Frame, Mounted on Side

Size	A	A / 2	B	C		D	E	Motor Frame Size Range				Weight (lbs)	
								Class I		Class II			
				Min	Max			Min	Max	I	II		
12	22.75	11.38	24.88	25.63	26.25	15.88	38.00	56	184	143	213	140	140
15	22.75	11.38	24.88	25.63	26.25	15.88	38.00	56	213	145	213	140	140
16	24.50	12.25	26.25	27.00	27.63	17.50	40.00	56	213	145	215	150	160

Dimensions shown are in inches.

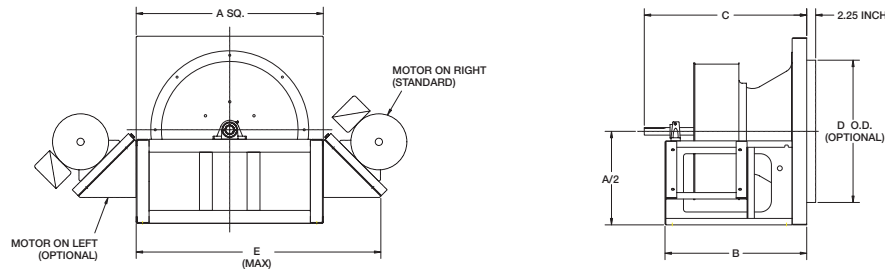

QEP Arrangement 1 - Horizontal, Motor on Frame, Mounted on Top

Size	A	A / 2	B	C		D	E	F	Motor Frame Size Range				Weight (lbs)	
									Class I		Class II			
				Min	Max				Min	Max	I	II		
12	22.75	11.38	24.88	25.63	26.25	15.88	35.00	26.75	56	184	143	213	130	150
15	22.75	11.38	24.88	25.63	26.25	15.88	35.00	26.75	56	213	145	213	140	150
16	24.50	12.25	26.25	27.00	27.63	17.50	36.75	28.50	56	213	145	215	160	160

Dimensions shown are in inches.

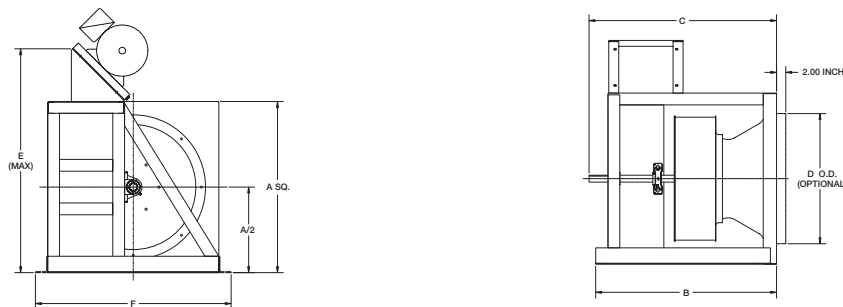

QEP Arrangement 1 - Vertical, Motor on Frame, Mounted on Side

Size	A	A / 2	B	C		D	E	F	Motor Frame Size Range				Weight (lbs)	
									Class I		Class II			
				Min	Max				Min	Max	I	II		
12	22.75	11.38	22.88	25.63	26.25	15.88	45.25	26.75	56	184	143	213	140	140
15	22.75	11.38	22.88	25.63	26.25	15.88	45.25	26.75	56	213	145	213	140	140
16	24.50	12.25	24.25	27.00	27.63	17.50	47.25	28.50	56	213	145	215	150	160

Dimensions shown are in inches.

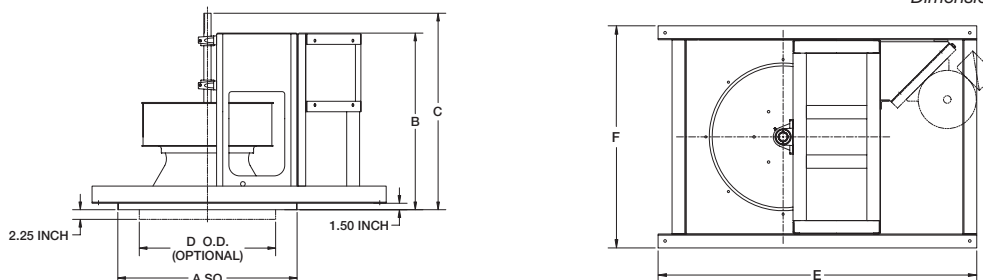

QEP Arrangement 3 - Horizontal, Motor off Frame

Size	A	A / 2	B	C			D	Weight (lbs)		
				I	II	III		I	II	III
18	27.50	13.75	21.25	24.63	25.88	25.88	19.25	120	130	140
20	29.50	14.75	22.75	26.13	27.38	27.38	21.13	140	170	170
22	31.50	15.75	25.38	28.75	29.38	30.63	23.00	180	210	220
24	35.50	17.75	27.13	30.50	31.13	32.38	25.88	230	240	270
27	37.50	18.75	29.13	33.13	33.75	34.38	28.50	250	260	300
30	41.75	20.88	31.75	35.75	36.38	37.63	31.75	320	340	410
33	44.75	22.38	34.88	38.88	40.13	40.75	34.88	360	400	480
36	48.50	24.25	37.63	41.63	42.88	44.88	38.50	410	490	530
40	52.50	26.25	40.50	45.13	45.75	47.75	42.00	500	580	620
44	58.00	29.00	44.50	49.13	50.38	53.00	46.50	600	710	770
49	62.50	31.25	48.13	53.38	54.00	56.63	51.00	790	820	980
54	68.00	34.00	52.75	58.00	60.00	61.25	56.50	960	1200	1300
60	75.00	37.50	58.50	63.75	67.00	69.00	62.50	1400	1500	1600
66	81.50	40.75	63.13	69.00	73.63	73.63	69.00	1600	1700	1800
73	92.00	46.00	69.25	75.13	77.75	79.75	76.00	2000	2100	2200

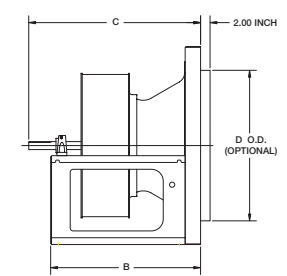
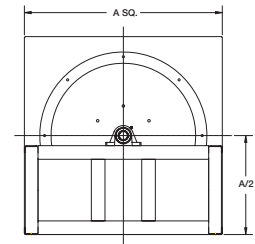

Dimensions shown are in inches.

QEP Arrangement 3 - Horizontal, Motor on Frame, Mounted on Top

Size	A	A / 2	B	C		D	E	F	Motor Frame Size Range				Weight (lbs)	
				I	II				Class I		Class II		I	II
									Min	Max	Min	Max		
18	27.50	13.75	23.25	24.63	25.88	19.25	39.75	31.50	56	213	145	215	180	190
20	29.50	14.75	25.75	26.13	27.38	21.13	43.00	35.50	56	215	182	254	200	240
22	31.50	15.75	28.38	28.75	29.38	23.00	45.00	37.50	56	215	182	254	240	290
24	35.50	17.75	30.13	30.50	31.13	25.88	49.00	41.50	56	254	184	256	310	320
27	37.50	18.75	32.13	33.13	33.75	28.50	51.00	43.50	56	256	213	256	340	350
30	41.75	20.88	34.75	35.75	36.38	31.75	55.75	47.75	56	256	213	284	420	450
33	44.75	22.38	37.88	38.88	40.13	34.88	58.75	50.75	56	284	215	286	480	510
36	48.50	24.25	40.63	41.63	42.88	38.50	64.75	54.50	143	284	215	324	530	610
40	52.50	26.25	43.50	45.13	45.75	42.00	68.75	58.50	145	286	254	326	630	720
44	58.00	29.00	47.50	49.13	50.38	46.50	74.25	64.00	145	324	256	326	760	870
49	62.50	31.25	51.13	53.38	54.00	51.00	78.75	68.50	182	326	284	326	960	990
54	68.00	34.00	56.75	58.00	60.00	56.50	86.25	76.00	182	364	286	364	1300	1400
60	75.00	37.50	62.50	63.75	67.00	62.50	93.25	83.00	184	364	286	365	1700	1800
66	81.50	40.75	67.13	69.00	73.63	69.00	99.75	89.50	184	365	324	365	1900	2000
73	92.00	46.00	73.25	75.13	77.75	76.00	110.30	100.00	213	365	326	365	2300	2400

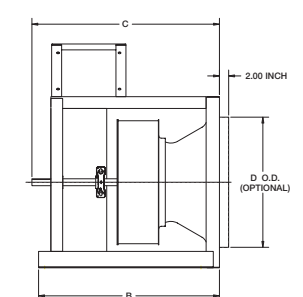
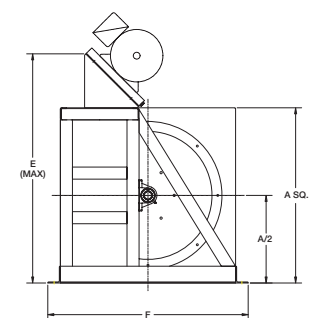

Dimensions shown are in inches.

Note: Sizes 12, 15, 16 available in arrangement 1 only
See pages 32 & 33

QEP Arrangement 3 - Horizontal Motor on Frame, Mounted on Side

Size	Dimensions				Class I					Class II				
					Frame Size		Dimensions		Weight (lbs)	Frame Size		Dimensions		Weight (lbs)
A	A / 2	B	D	Min	Max	C	E	Min		Max	C	E		
18	27.50	13.75	21.25	19.25	56	56	24.63	35.00	140	Not available				
					143	213		43.00	170	145	215	25.88	43.00	180
20	29.50	14.75	25.75	21.13	56	56	26.13	37.00	150	Not available				
					143	215		45.00	200	182	254	27.38	45.00	240
22	31.50	15.75	28.38	23.00	56	56	28.75	39.00	190	Not available				
					143	215		46.00	230	182	254	29.38	46.00	280
24	35.50	17.75	30.13	25.88	56	145	30.50	43.00	240	Not available				
					182	254		53.00	300	184	256	31.13	53.00	310
27	37.50	18.75	32.13	28.50	56	145	33.13	45.00	270	Not available				
					182	256		55.00	330	213	256	33.75	55.00	340
30	41.75	20.88	34.75	31.75	56	184	35.75	51.50	350	Not available				
					213	256		58.00	400	213	284	36.38	61.75	430
33	44.75	22.38	37.88	34.88	56	184	38.88	54.50	390	Not available				
					213	284		63.75	460	215	286	40.13	63.75	490
36	48.50	24.25	40.63	38.50	143	184	41.63	58.25	430	Not available				
					213	284		66.75	500	215	324	42.88	71.75	610
40	52.50	26.25	43.50	42.00	145	184	45.13	62.25	530	Not available				
					213	286		68.50	600	254	326	45.75	75.25	700
44	58.00	29.00	47.50	46.50	145	215	49.13	70.25	640	Not available				
					254	324		79.25	720	256	326	50.38	79.25	840
49	62.50	31.25	51.13	51.00	182	215	53.38	74.75	840	Not available				
					254	326		80.75	920	284	326	54.00	80.75	950
54	68.00	34.00	56.75	56.50	182	256	58.00	81.50	1100	Not available				
					284	364		89.50	1200	286	364	60.00	89.50	1400
60	75.00	37.50	62.50	62.50	184	286	63.75	89.00	1500	286	286	67.00	89.00	1600
					324	365		95.50	1700	324	365		95.50	1700
66	81.50	40.75	67.13	69.00	184	286	69.00	95.50	1700	Not available				
					324	365		102.00	1800	324	365	73.63	102.00	1900
73	92.00	46.00	73.25	76.00	213	326	75.13	108.25	2000	326	326	77.75	108.25	2200
					364	365		112.80	2200	364	365		112.80	2300

Dimensions shown are in inches.

QEP Arrangement 3 - Vertical, Motor on Frame, Mounted on Side

Size	A	B	C		D	E		F	Motor Frame Size Range				Weight (lbs)	
									Class I		Class II			
			I	II		Min	Max		Min	Max	I	II		
18	27.50	21.25	24.63	25.88	19.25	50.25	50.25	31.50	143	213	145	215	210	220
20	29.50	22.75	26.13	27.38	21.13	53.50	56.00	35.50	143	215	182	254	260	300
22	31.50	25.38	28.75	29.38	23.00	54.50	58.00	37.50	143	215	182	254	300	340
24	35.50	27.13	30.50	31.13	25.88	62.00	62.00	41.50	182	254	184	256	370	380
27	37.50	29.13	33.13	33.75	28.50	64.00	64.00	43.50	182	256	213	256	400	410
30	41.75	31.75	35.75	36.38	31.75	66.63	70.38	47.75	213	256	213	284	480	510
33	44.75	34.88	38.88	40.13	34.88	72.38	72.38	50.75	213	284	215	286	540	570
36	48.50	37.63	41.63	42.88	38.50	75.38	80.38	54.50	213	284	215	324	600	720
40	52.50	40.50	45.13	45.75	42.00	77.13	83.88	58.50	213	286	254	326	700	810
44	58.00	44.50	49.13	50.38	46.50	87.63	87.63	64.00	254	324	256	326	840	950
49	62.50	48.13	53.38	54.00	51.00	89.13	89.13	68.50	254	326	284	326	1100	1100
54	68.00	52.75	58.00	60.00	56.50	99.38	99.38	76.00	284	364	286	364	1400	1600

Dimensions shown are in inches.

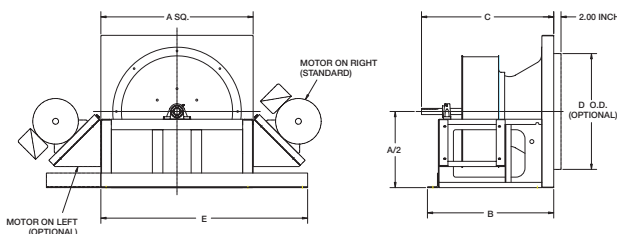

Horizontal

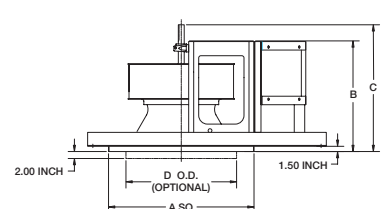
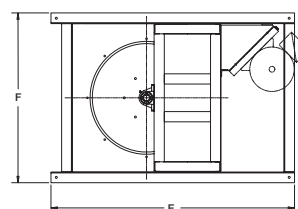

Vertical

Design and Selection Support

Computer Aided Product Selection Program – CAPS

All Greenheck products are supported by the industry's best product literature, electronic media, and Computer Aided Product Selection program, CAPS. Online, you can also find electronic copies of our product literature as well as storage, installation and maintenance information in our Installation and Operation Manuals.

And, of course, you can always count on the personal service and expertise of our national and international representative organization. To locate your nearest Greenheck representative call 715-359-6171 or visit our website at www.greenheck.com

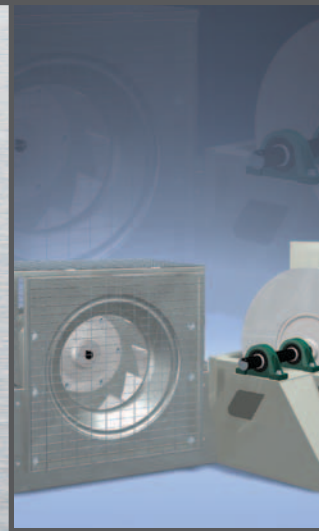

To-Scale Drawings and Fan Specifications

To-scale CAD drawings along with detailed centrifugal specifications can be found online at www.greenheck.com or within our Computer Aided Product Selection program (CAPS).

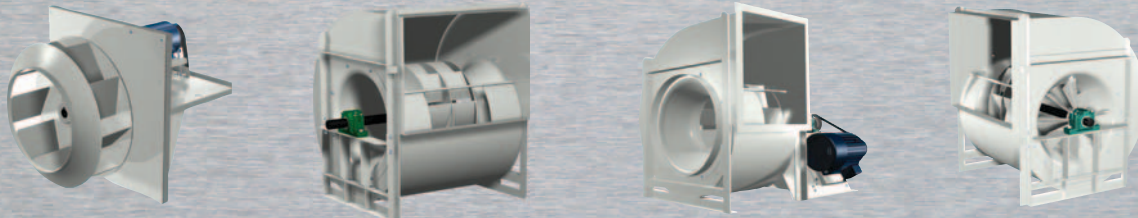

Building Value in Air

Greenheck delivers value to mechanical engineers by helping them solve virtually any air quality challenges their clients face with a comprehensive selection of

top quality, innovative air-related equipment. We offer extra value to contractors by providing easy-to-install, competitively priced, reliable products that arrive on time.

And building owners and occupants value the energy efficiency, low maintenance and quiet dependable operation they experience long after the construction project ends.

Our Warranty

Greenheck warrants this equipment to be free from defects in material and workmanship for a period of one year from the purchase date. Any units or parts which prove defective during the warranty period will be replaced at our option when returned to our factory, transportation prepaid. Motors are warranted by the motor manufacturer for a period of one year. Should motors furnished by Greenheck prove defective during this period, they should be returned to the nearest authorized motor service station. Greenheck will not be responsible for any removal or installation costs.

As a result of our commitment to continuous improvement, Greenheck reserves the right to change specifications without notice.



Prepared to Support Green Building Efforts

